

WELCOME TO THE COMMERCIAL RANGE

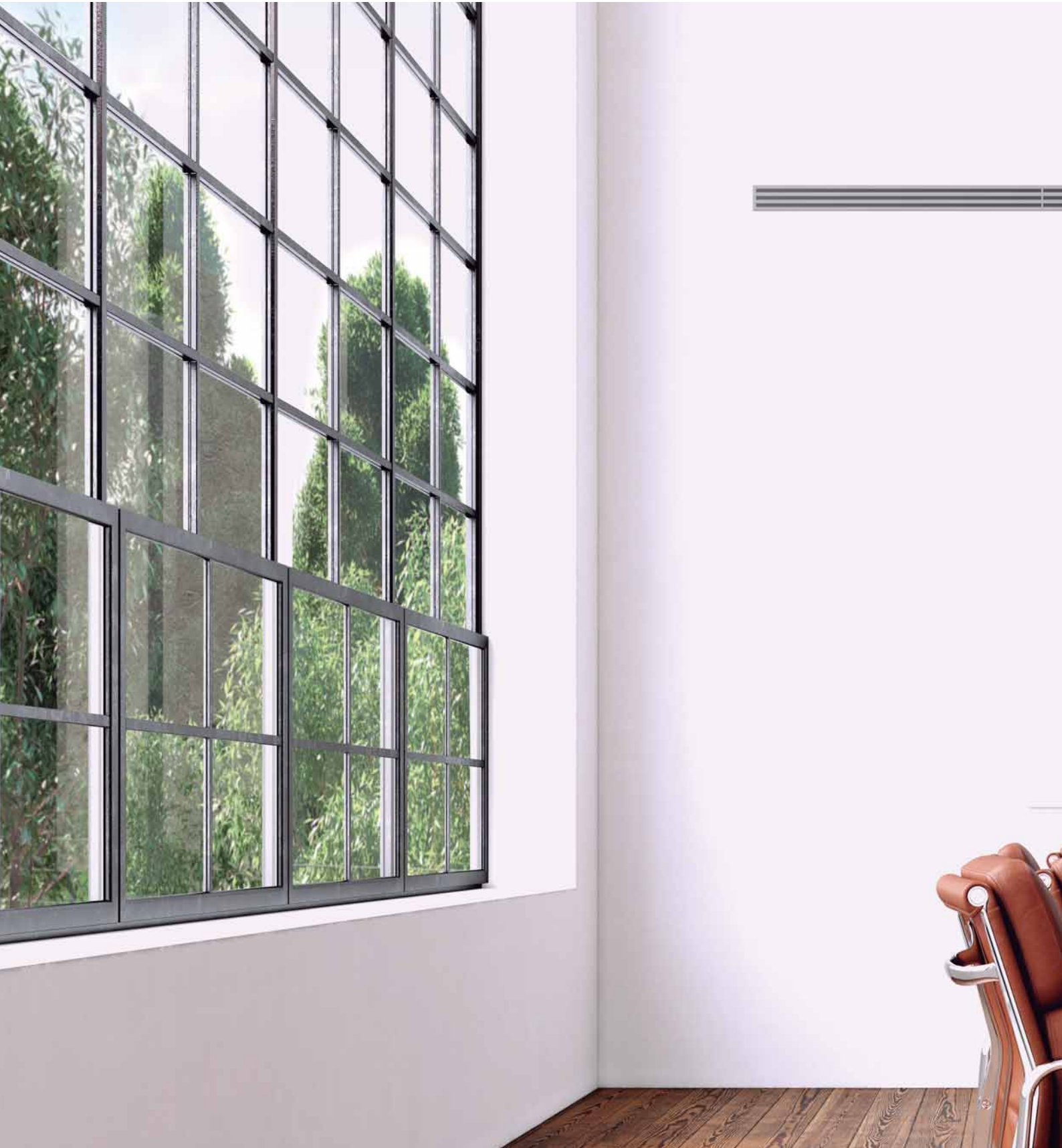

Here are some of your new air conditioner's major features.
Panasonic has developed an impressive range of highly efficient Commercial Air Conditioners. This range confirms our commitment to the environment. Our Inverter compressors optimise performance.



HIGHLIGHTED FEATURES

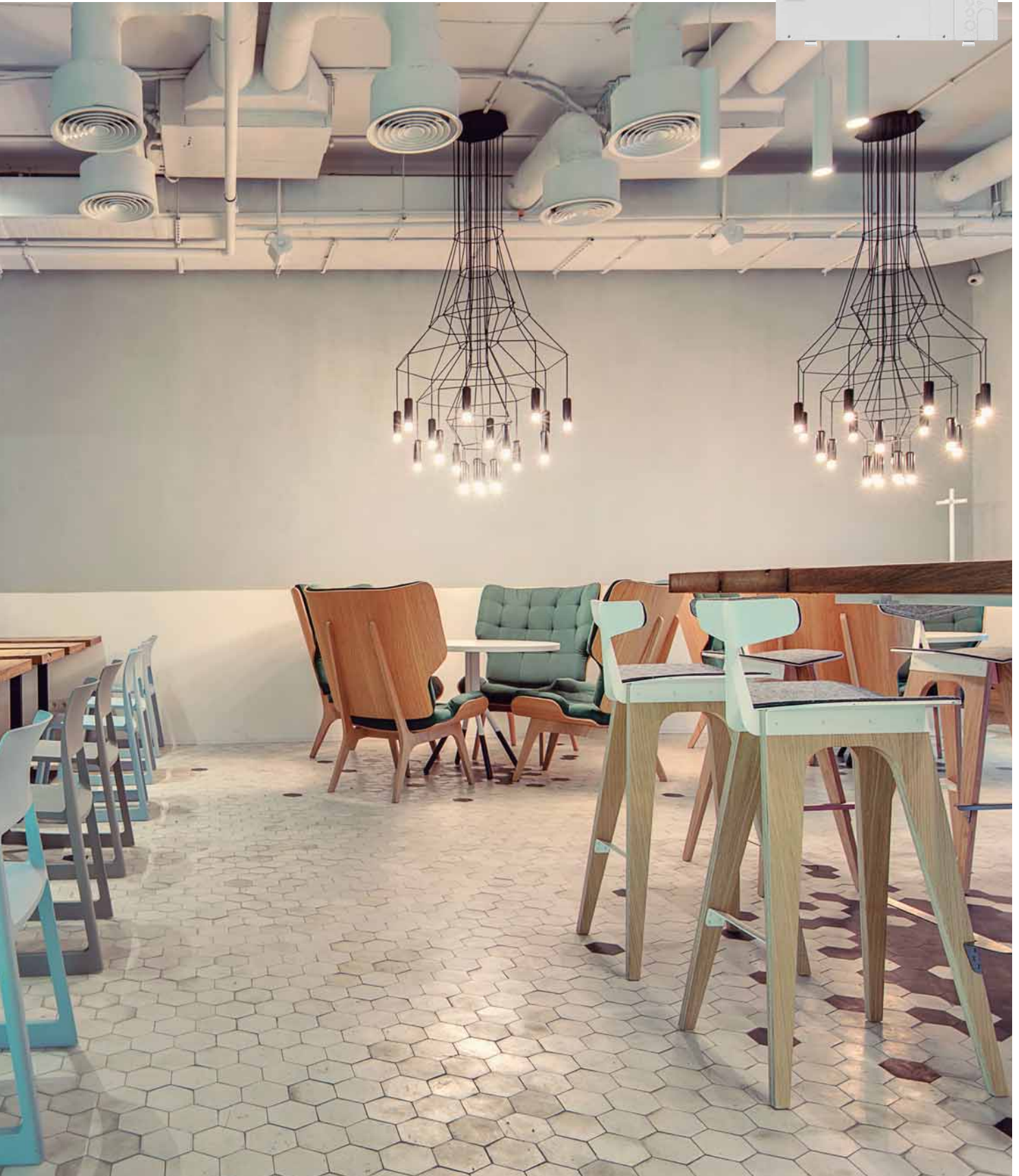



PACi: Commercial air to air. The full solution for shops, restaurants, offices or residential applications with high efficiency and compact in size.

Commercial benefits

Great savings and improved wellness.

Panasonic has developed an impressive range of highly efficient Commercial Air Conditioners. Our Inverter compressors optimise performance.

A wide range for the commerce, office or residence.

From the smaller 1x1 to the more complete 4x1 solutions, it doesn't

matter which your need is. Panasonic can offers you the best solution to get the best clima.

High connectivity.

The control systems allows you to have complete control of all your installations. All your units from several locations, receive status updates in real-time, preventing breakdowns and optimizing costs.

Energy saving



Intelligent Human Activity Sensor and Sunlight Sensor technologies that can detect and reduce waste of energy by optimising air conditioner operation according to room conditions. With just one touch of a button, you can save energy.

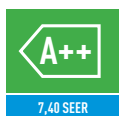

Exceptional Seasonal Cooling Efficiency based on the new ErP regulation. Higher SEER ratings mean greater efficiency. Save all the year while cooling!



Exceptional Seasonal Heating Efficiency based on the new ErP regulation. Higher SCOP ratings mean greater efficiency. Save all the year while heating!



Inverter Plus System classification highlight the Panasonic highest performing systems.



Wider operation Hz range of compressor realize more high efficient operation through the year. For Big PACi Series PEZ.



Our heat pumps containing the new refrigerant R32 show a drastic reduction in the value of Global Warming Potential (GWP). An important step to reduce greenhouse gases. R32 is also a components refrigerant, making it easy to recycle.

High performance

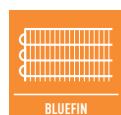

Panasonic has extended the life of its condensers with an original anti-rust coating. For Big PACi Series PEZ.



Big size Fan makes larger airflow rate and very silent operation at low speed. For Big PACi Series PEZ.



DC Fan: Save and precise.



The air conditioner works in cooling mode with an outdoor temperature of -15°C.



The air conditioner works in heat pump mode even when outdoor temperatures are as low as -20°C or -15°C.

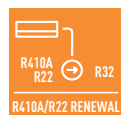

The Panasonic renewal system allows good quality existing R410A or R22 pipe work to be re-used whilst installing new high efficiency R32 systems.



The Panasonic renewal system allows good quality existing R22 pipe work to be re-used whilst installing new high efficiency R410A systems.



5 years warranty. We guarantee the outdoor unit compressors in the entire range for five years.

High connectivity



The AC Smart Cloud from Panasonic allows you to have complete control of all your installations. In a simple click, all your units from several locations, receive status updates in real-time of all your installations, preventing breakdowns and optimizing costs.



Internet Control is a next generation system providing a user-friendly remote control of air conditioning or heat pump units from everywhere, using a simple Android or iOS smartphone, tablet or PC via internet.



The communication port is integrated into the indoor unit and provides easy connection to, and control of, your Panasonic heat pump to your home or building management system.

PACi OUTDOOR UNITS ENERGY SAVING CONCEPT



Product quality and safety. All Panasonic air conditioners undergo strict quality and safety tests before sale. This rigorous process includes obtaining all necessary safety approvals, to ensure that all air conditioners we sell are not only built to the highest market standards, but are also completely safe.



New PACi R32 Refrigerant Gas

Panasonic recommended R32 because it is comparably environmentally friendly. Compared to R22 and R410A, R32 has a very low potential impact on the depletion of ozone layer and global warming.

In line with the European Countries who are concerned in protecting and maintaining the environment by participating in the Montreal Protocol to rectify one of its program in protecting the Ozone Layer and preventing Global Warming, Panasonic is leading the switch to R32.

PACi Elite: Newly designed next generation of commercial air conditioning

Outstanding performance at low temperatures, high energy efficiency, power consumption in remote control display. Energy-saving concept. The use of energy saving design for the structure of fans, fan motors, compressors and heat exchangers resulted in high COP value which ranked as one the top class in the industry. CO₂ emissions through reduced energy consumption and lowers operating costs.

PACi Elite. From 3,6 to 25,0kW.

- Meeting all necessary safety approvals to ensure quality and safety
- Top-class SEER: A++ / SCOP: A++ at 10,0kW (in 90x90 Cassette)
- Cooling operation is possible when outdoor temperature as high as 46°C
- DC inverter technology combined with R410A
- Cooling operation is possible when outdoor temperature as low as -15°C
- Heating operation is possible when outdoor temperature as low as -20°C
- Compact outdoor units
- Auto restart from outdoor unit
- Twin, Triple and Doble-Twin connection possible

Panasonic Mini PACi Series PE2

Outdoor PACi Elite from 3,6kW to 6,0kW and PACi Standard 6,0kW to 7,1kW, all made in Japan.

Fully new outdoor design with last generation compressor. Higher performance and better partial load. Includes control consumption, 0-10V demand control and all latest remote controller's functionalities.

High efficiency:

- New heat exchanger
- New and bigger fan
- New Panasonic Compressor
- New chassis

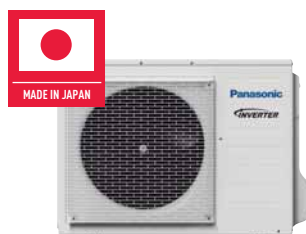

1. Installation innovation.

- Extremely easy to install, practically the same as for the R410A. (Just remember to verify that the pressure gauge and vacuum pump are compatible with the R32)
- This refrigerant is 100% pure, which makes it easier to recycle and reuse

2. Environmental innovation.

- Zero impact on the ozone layer
- 75% less impact on global warming

3. Economic and energy consumption innovation.

- Lower cost and greater savings
- Higher energy efficiency than R410A

PACi Standard: For economy and value

With high quality design and engineering, the PACi Standard is the perfect solution for projects which demand quality on a limited budget. In addition, its compact size and light weight make it ideal for installations with limited space including small commercial and residential applications.

The outdoor unit is much more compact than the previous model. The slim and lightweight design means the PACi outdoor unit can be installed in a number of situations. On the 12,5kW (996x940x340mm).

PACi Standard. From 6,0 to 14,0kW.

- Good balance, system cost vs energy efficiency
- Top class SEER/SCOP as a Standard Inverter category SEER: A++ / SCOP: A+ at 10,0kW (in 90x90 Cassette)
- Interchangeable controller with ECOi
- Compact outdoor units
- Twin connection possible
- Cooling operation up to -10°C
- Heating operation up to -15°C

Big PACi Elite. Trusted power and high efficiency

PACi 8 and 10HP are designed to adapt to current and most demanding commercial needs. Ready to connect to 1 big ducted indoor unit up to 4 indoor units.

Large capacity PACi Elite:

- High efficiency
- Better partial load (10% ~ 100%)
- More flexible piping
- Bluefin anti-rust coating
- 0-10V control demand
- Energy saving functions
- AHU connection kit
- From 1 to 4 indoor units



PACi ELITE: EXCELLENT SEER AND SCOP VALUES



High operating efficiency using DC inverter compressor, DC motor and a heat exchanger design.

Seasonal efficiency for daily energy saving

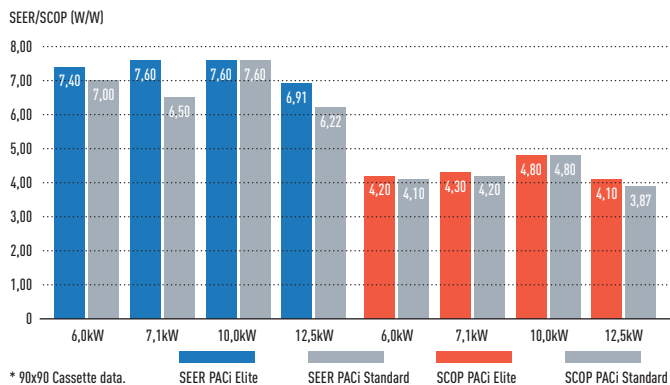

Increased piping length for greater design flexibility

Adaptable to various building types and sizes.
Maximum piping length: 75m (10.0, 12.5, 14.0kW). 50m (6.0, 7.1kW).

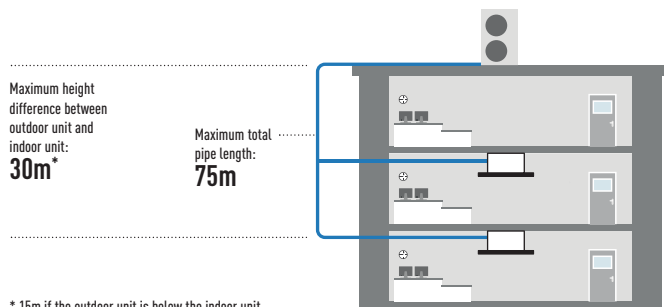

Design operation conditions

Cooling operation is possible when outdoor temperature as low as -15°C or as high as 46°C. Heating operation is possible when outdoor temperature as low as -20°C. The remote control temperature setting offers a range from 18°C to 30°C.

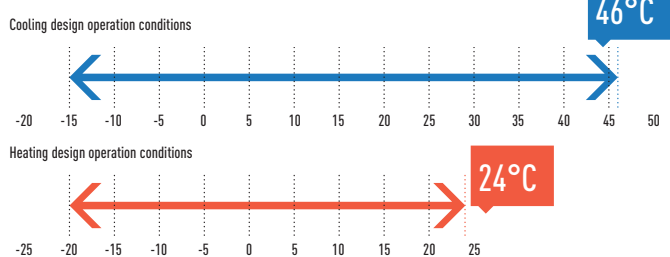

Compact & Flexible-design

The slim and lightweight design means the PACi outdoor unit can be installed in a number of compact situations. As the unit only weighs 98kg, it is easy to carry and easy to install.

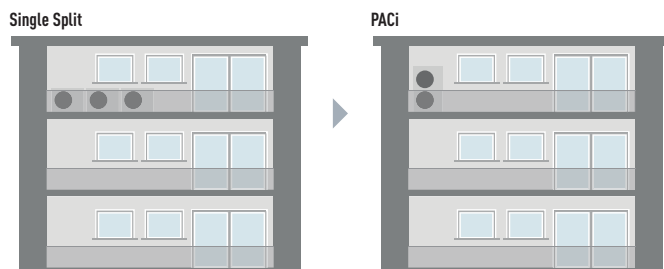

Energy consumption monitoring display with the CZ-RTC5B

Menu selection: 3 types (Day/Week/Year) of display are available.

Daily Energy consumption: Data is shown with Yesterday's record. (Graph starts from 0 o'clock to 24 o'clock only.)

Weekly Energy consumption: Power consumption of each day of the week can be checked.

Annual Energy consumption: Power consumption of each month can be checked.



New datanavi, a new way to connect.
Simple and easy support tool with your smartphone.



Demand response compliant (CZ-CAPDC3) as a standard function

This terminal allows demand control of the outdoor unit. Several level of settings are available:

- Level-1, 2, 3 : 75 / 50 / 0 %
- Level-1, 2 can be set in 40 - 100% (40, 45, 50...95, 100: each 5%)

Demand control terminal is available to control 0-50-75% of capacities. CZ-CAPDC3 is an optional for R410A models.

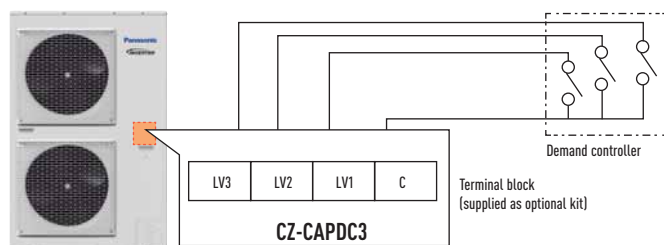

SOLUTIONS FOR SERVER ROOMS



High efficiency products for 24/7 applications. Panasonic has developed a complete range of solutions for server rooms which efficiently protect your servers, keeping them at an appropriate temperature even when the outdoor temperature is below -20°C.



High efficiency all the year

Key points:

- **NEW!** From 2,5 to 7,1kW with new TKEA R32 gas units A+++ in cooling
- PACi units from 3,6 to 14kW
- Backup function
- Redundancy function
- Alternative run function
- Error information by dry contact
- Operation even at -20°C outdoor temperature
- High seasonal performance
- Product design for 24/7 operation

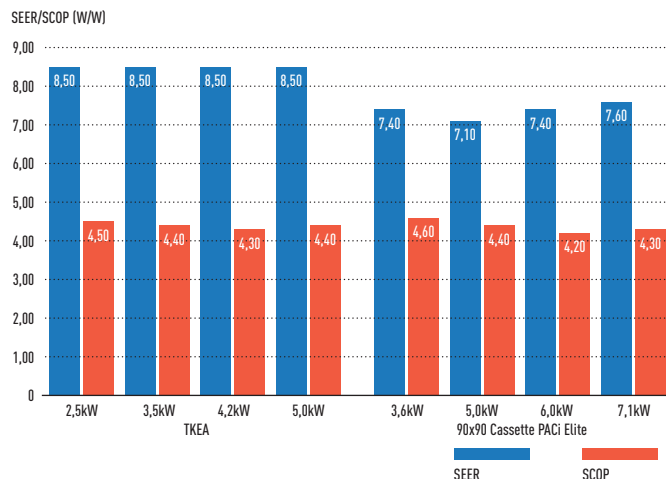

Interface to run 2 TKEA/PKEA. PAW-SERVER-PKEA

The PAW-SERVER-PKEA server room interface manages redundancy and backup of two TKEA/PKEA units with two different selectable modes:

- Plug and play by embedded redundancy and backup algorithm (no external signal needed. Further details please refer to operation manual)
- External (third party PLC) redundancy and backup management by dry contact

All settings are possible without the need for a computer connection. A special Energy Saving Mode is selectable by deep switch (available only in plug and play mode). The level of remote control input prohibition can be set when external management is by dry contact.

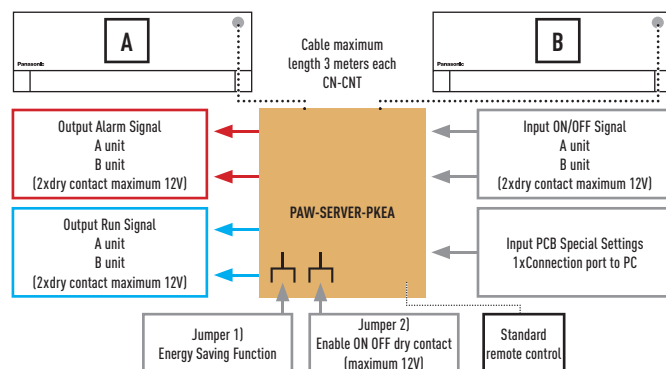

Interfaces to run 2 or up to 3 PACi and VRF Range

PAW-PACR3.

In combination with one PAW-T10V on each indoor unit, allows the redundant operation of 2 (or 3) PACi or VRF indoor units. All units will be operated by programmable turns in order to achieve the same operating time (example turn every 8 hours with 24 hours). If the room temperature exceeds a freely set value, the 2nd (or 3rd) unit will be switched ON and an alarm will be activated.

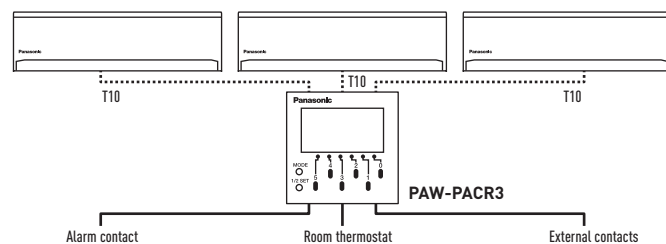

- Display and Settings:**
- Possible to select next unit manually
 - Possible to reset operation
 - LED display shows operation status of the 2 or 3 units
 - Operation status output
 - Alarm LED and alarm output
 - Temperature limit can be set
 - Temperature hysteresis can be set
 - Room temperature is displayed
 - Time counter displayed

Backup control by using. CZ-RTC5B.

Group wiring of 2 systems of PACi can do auto individual control.

- Rotation operation
- Backup operation
- Support operation

CZ-CAPRA1.

Domestic with CZ-CNT port integration to PACi and ECOi.

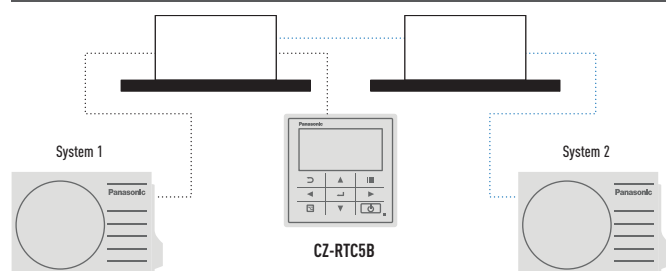

GENERATION PACi 90x90 CASSETTE



Panasonic introduces new flat panel design which is modern and matching well with your space. These cassettes have developed to satisfy today's customer needs such as high energy saving, comfort and healthier air.

PACi Cassette Panasonic

- Better SCOP & SEER (up to 15%)
- Advanced comfort and energy saving by Econavi sensor
- Air purification nanoe™ X system
- Super quiet operation from 28dB(A)

These cassettes offer upgraded Econavi and nanoe™ X purification system as accessories for making application space more comfortable, healthy and efficient.



Always fresh and clean air with nanoe™ X

- nanoe™ X is available by the advanced technology of room air conditioning.
- Purificating operation can work simultaneously or independently from heating/cooling operation.
 - Inhibiting certain viruses, bacteria & deodorisation (bacteria, fungus, pollen, virus and cigarette smoke). OH radicals in nanoe™ X pull bacteria's hydrogen out and it is effectively deodorised and sterilised
 - Clean inside by nanoe™ X + Dry control: inside of indoor unit can be cleaned by short operation circuit with nanoe™ X and drying

CZ-RTC5B and optional accessory CZ-CNEXU1 are required to use nanoe™ X function.

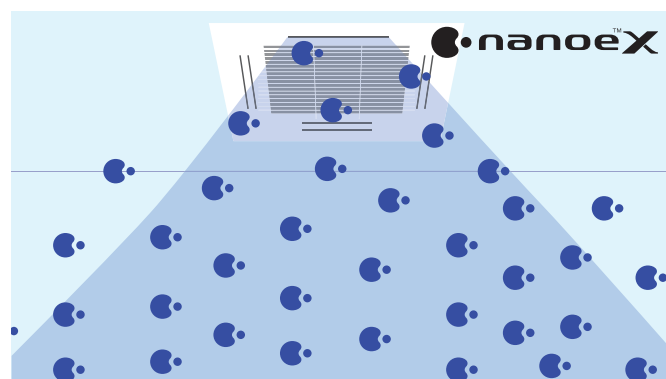

Econavi intelligent sensor

Human activity sensor and floor temperature sensor can reduce waste of energy by optimising air conditioner operation.



Advanced Econavi functions.

2 sensors (movement and floor temperature) can find waste of energy and control effectively. Floor temperature can detect up to 5m ceiling height.

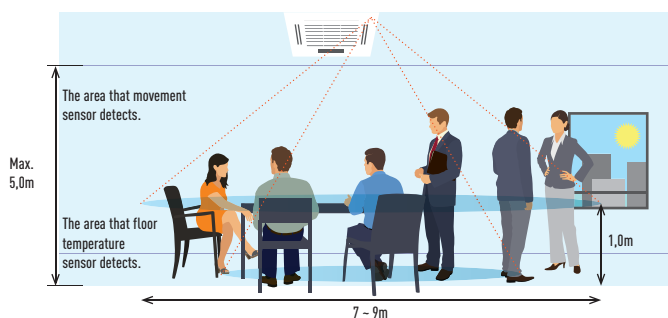

Econavi exclusive panel. Optional (CZ-KPU3A)



Floor temperature sensor.
This sensor detects average floor temperature and operates circulation if floor is low temperature.



Movement sensor.
This sensor detects the amount of human activity, and operates effectively.

Wired remote controller CZ-RTC5B is required.

Humidity sensor.

Humidity sensor has added on air suction part, and realises comfort and energy saving based on temperature and humidity.

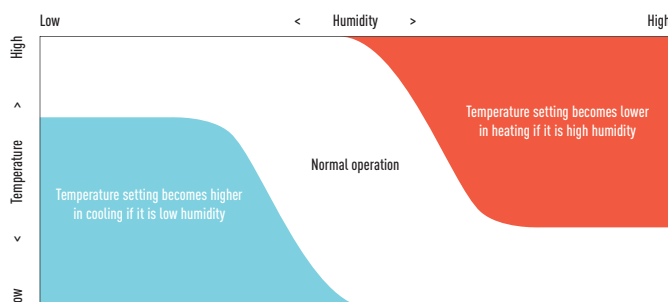





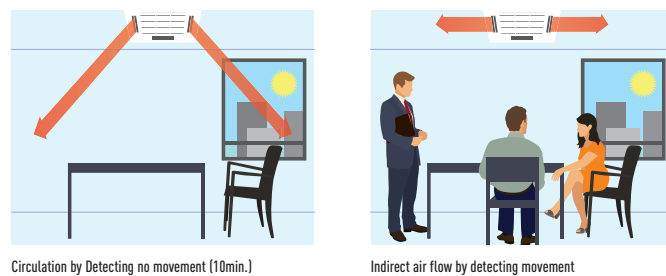

























Group control, circulation function.

Circulating operation is activated when nobody is there, and mix air in the whole room. Minimize temperature gap in both heating and cooling operation.













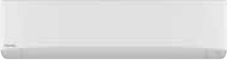
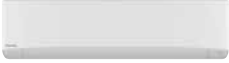
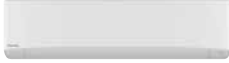











RANGE OF COMMERCIAL UNITS R32

Page	Indoor units	2,5kW	3,5 ~ 3,6kW	4,5kW	5,0kW
P. 82	NEW Wall Mounted Professional Inverter -20°C • R32 GAS	 KIT-E25-TKEA	 KIT-E35-TKEA	 KIT-E42-TKEA	 KIT-E50-TKEA
P. 84	NEW Wall Inverter+ • R32 GAS		 S-36PK2E5B	 S-45PK2E5B	 S-50PK2E5B
Check it in RAC part	NEW 4 Way 60x60 Cassette Inverter • R32 GAS	 KIT-Z25-UB4	 KIT-Z35-UB4		 KIT-Z50-UB4
	NEW 4 Way 60x60 Cassette Inverter+ • R32 GAS		 S-36PY2E5B*	 S-45PY2E5B*	 S-50PY2E5B*
P. 86	NEW 4 Way 90x90 Cassette Inverter+ • R32 GAS		 S-36PU2E5B	 S-45PU2E5B	 S-50PU2E5B
P. 88	NEW Ceiling Inverter+ • R32 GAS		 S-36PT2E5B	 S-45PT2E5B	 S-50PT2E5B
Check it in RAC part	NEW Low Static Pressure Hide Away Inverter • R32 GAS	 KIT-Z25-UD3	 KIT-Z35-UD3		 KIT-Z50-UD3
P. 90	NEW High Static Pressure Hide Away Inverter+ • R32 GAS		 S-36PF1E5B	 S-45PF1E5B	 S-50PF1E5B
	NEW Low Static Pressure Hide Away Inverter+ • R32 GAS		 S-36PN1E5B*	 S-45PN1E5B*	 S-50PN1E5B*
Outdoor units PACi Elite and Standard			3,6kW		5,0kW
	NEW PACi Elite • R32 GAS		 U-36PZH2E5*		 U-50PZH2E5*
	NEW PACi Standard • R32 GAS				

* These models will be available in Autumn 2018. U__E5 Single Phase / U__E8 Three Phase.

PACi Kits

R32

6,0kW	7,1kW	10,0kW	12,5kW	14,0kW
				
	KIT-E71-TKEA			
				
S-60PK2E5B	S-71PK2E5B	S-100PK2E5B (9,0kW)		
				
KIT-Z60-UB4				
				
S-60PU2E5B	S-71PU2E5B	S-100PU2E5B	S-125PU2E5B	S-140PU2E5B
				
S-60PT2E5B	S-71PT2E5B	S-100PT2E5B	S-125PT2E5B	S-140PT2E5B
				
KIT-Z60-UD3				
				
S-60PF1E5B	S-71PF1E5B	S-100PF1E5B	S-125PF1E5B	S-140PF1E5B
				
S-60PN1E5B*	S-71PN1E5B*	S-100PN1E5B*	S-125PN1E5B*	S-140PN1E5B*

6,0kW	7,1kW	10,0kW	12,5kW	14,0kW
				
U-60PZH2E5*	U-71PZH2E5* / U-71PZH2E8*	U-100PZH2E5* / U-100PZH2E8*	U-125PZH2E5* / U-125PZH2E8*	U-140PZH2E5* / U-140PZH2E8*
				
U-60PZ2E5*	U-71PZ2E5*	U-100PZ2E5 / U-100PZ2E8	U-125PZ2E5 / U-125PZ2E8	U-140PZ2E5 / U-140PZ2E8

NEW WALL MOUNTED PROFESSIONAL INVERTER -20°C • R32 GAS



High efficiency products for 24/7 applications. Panasonic has developed a complete range of solutions for server rooms which efficiently protect your servers, keeping them at an appropriate temperature even when the outdoor temperature is below -20°C.

High efficiency all the year

Key points:

- **NEW!** From 2,5 to 7,1kW with New TKEA R32 gas units
- Backup function
- Redundancy function
- Alternative run function
- Error information by dry contact
- Operation even at -20°C outdoor temperature
- High seasonal performance
- Product design for 24/7 operation

Splits 1x1

R32



Complete line-up with high efficiency even at -20°C.

This Wall Mounted air conditioner is especially designed for professional applications such as computer rooms where cooling inside the room is necessary even when the outside temperature is low. Furthermore this air conditioner has an automatic changeover system, in order to maintain the inside temperature even when sharp outside temperature changes occur.

Technical focus

- **NEW!** New design
- R32 gas is more environmentally friendly than R410A
- Designed for 24h/7d a week operation
- Up to A+++ in cooling
- Highly efficient even at -20°C
- High durability rolling bearings
- Additional piping sensors to prevent freezing

KIT			KIT-Z25-TKEA	KIT-Z35-TKEA	KIT-Z42-TKEA	KIT-Z50-TKEA	KIT-Z71-TKEA
Cooling capacity	Nominal (Min - Max)	kW	2,50 [0,85 - 3,00]	3,50 [0,85 - 4,00]	4,20 [0,98 - 5,00]	5,00 [0,98 - 6,00]	7,10 [0,98 - 8,10]
EER ¹⁾	Nominal (Min - Max)	W/W	4,90 [5,00 - 4,29] A	4,07 [5,00 - 3,64] A	3,82 [4,90 - 3,25] A	3,60 [3,50 - 3,09] A	3,17 [2,33 - 3,03] B
SEER ²⁾		W/W	8,50 A+++	8,50 A+++	8,50 A+++	8,50 A+++	6,10 A++
Pdesign		kW	2,50	3,50	4,20	5,00	7,10
Input power cooling	Nominal (Min - Max)	kW	0,51 [0,17 - 0,70]	0,86 [0,17 - 1,10]	1,10 [0,20 - 1,54]	1,39 [0,28 - 1,94]	2,24 [0,42 - 2,67]
Annual energy consumption ³⁾		kWh/a	103	144	173	206	407
Heating capacity	Nominal (Min - Max)	kW	3,40 [0,85 - 5,40]	4,00 [0,85 - 6,60]	5,40 [0,98 - 7,25]	5,80 [0,98 - 8,00]	8,60 [0,98 - 9,90]
Heating capacity at -7°C		kW	3,33	4,07	4,30	5,00	6,13
COP ¹⁾	Nominal (Min - Max)	W/W	4,86 [5,15 - 4,12] A	4,35 [5,15 - 3,63] A	4,00 [4,45 - 3,37] A	4,03 [2,88 - 3,20] A	3,51 [2,45 - 3,47] B
SCOP ²⁾		W/W	4,50 A+	4,40 A+	4,30 A+	4,40 A+	4,00 A+
Pdesign at -10°C		kW	2,80	3,60	3,80	4,40	5,50
Input power heating	Nominal (Min - Max)	kW	0,70 [0,17 - 1,31]	0,92 [0,17 - 1,82]	1,35 [0,22 - 2,15]	1,44 [0,34 - 2,50]	2,45 [0,40 - 2,85]
Annual energy consumption ³⁾		kWh/a	871	1145	1237	1400	1925
Indoor unit			CS-Z25TKEA	CS-Z35TKEA	CS-Z42TKEA	CS-Z50TKEA	CS-Z71TKEA
Power source		V	230	230	230	230	230
Recommended fuse		A	16	16	16	16	20
Connection indoor / outdoor		mm ²	4 x 1,5	4 x 1,5	4 x 1,5	4 x 2,5	4 x 2,5
Air Volume	Cool / Heat	m ³ /min	10,40 / 11,70	10,70 / 12,40	18,20 / 20,20	19,20 / 21,30	20,20 / 21,00
Moisture removal volume		L/h	1,5	2,0	2,4	2,8	4,1
Sound pressure ⁴⁾	Cool (Hi / Lo / Q-Lo)	dB(A)	39 / 25 / 21	42 / 28 / 21	43 / 32 / 29	44 / 37 / 30	47 / 38 / 35
	Heat (Hi / Lo / Q-Lo)	dB(A)	41 / 27 / 22	43 / 30 / 22	44 / 35 / 29	44 / 37 / 30	47 / 38 / 35
Dimension	H x W x D	mm	295 x 919 x 194	295 x 919 x 194	302 x 1120 x 236	302 x 1120 x 236	302 x 1120 x 236
Net weight		kg	9	10	12	12	13
Outdoor unit			CU-Z25TKEA	CU-Z35TKEA	CU-Z42TKEA	CU-Z50TKEA	CU-Z71TKEA
Sound pressure ⁴⁾	Cool / Heat (Hi)	dB(A)	46 / 48	48 / 50	48 / 50	48 / 50	52 / 54
Dimension ⁵⁾	H x W x D	mm	619 x 824 x 299	619 x 824 x 299	619 x 824 x 299	695 x 875 x 320	695 x 875 x 320
Net weight		kg	37	38	38	43	49
Piping connections	Liquid pipe	Inch (mm)	1/4 (6,35)	1/4 (6,35)	1/4 (6,35)	1/4 (6,35)	1/4 (6,35)
	Gas pipe	Inch (mm)	3/8 (9,52)	3/8 (9,52)	1/2 (12,70)	1/2 (12,70)	5/8 (15,88)
Pipe length range		m	3 - 20	3 - 20	3 - 20	3 - 30	3 - 30
Elevation difference (in/out) ⁶⁾		m	15	15	15	15	20
Pipe length for additional gas		m	7,5	7,5	7,5	7,5	10
Additional gas amount		g/m	10	10	10	15	25
Refrigerant (R32)		kg / TCO ₂ Eq.	0,96 / 0,648	1,00 / 0,675	1,08 / 0,729	1,15 / 0,776	1,32 / 0,891
Operating range	Cool Min ~ Max	°C	-20 ~ +43	-20 ~ +43	-20 ~ +43	-20 ~ +43	-20 ~ +43
	Heat Min ~ Max	°C	-15 ~ +24	-15 ~ +24	-15 ~ +24	-15 ~ +24	-15 ~ +24

Accessories

CZ-TACG1	NEW Panasonic Wifi kit for internet control
CZ-CAPRA1	RAC interface adapter for integration into P Link
PAW-WTRAY	Tray for condenser water compatible with base ground support

Accessories

PAW-GRDSTD40	Outdoor elevation platform
PAW-GRDBSE20	Outdoor base ground support for noise and vibration absorption
PAW-SERVER-PKEA	PCB for installation in server rooms with security

1) EER and COP calculation is based in accordance to EN14511. 2) Energy Label Scale from A+++ to D. 3) The annual energy consumption is calculated in accordance to EU/626/2011. 4) The sound pressure of the units shows the value measured of a position 1m in front of the main body and 0,8m below the unit. The sound pressure is measured in accordance with Eurovent 6/C/006-97 specification. Q-Lo: Quiet mode. Lo: The lowest fan speed. 5) Add 70mm for piping port. 6) When installing the outdoor unit at a higher position than the indoor unit.



SEER and SCOP: For KIT-Z25-TKEA. SUPER QUIET: For KIT-Z25-TKEA. INTERNET CONTROL: Optional.

NEW PACi STANDARD WALL MOUNTED INVERTER+ • R32 GAS

NEW
18



The range units allows for many more applications such as studios, gyms, high ceiling areas and even computer server rooms.

The unit's compact design and flat face ensure discreet installation, even in a small space.

High heating capacity at -7°C.

Technical focus

- Flat face and compact design for modern appearance
- Stylish matt white color
- DC FAN for better efficiency and control
- Six directional piping outlet
- Easy connection and control of external fan or ERV using the connector PAW-FDC on the indoor unit PCB. The external device can be control by the remote control of the Panasonic indoor unit

Tentative data			Single Phase
KIT			9,0kW
Remote controller			KIT-100PK2Z5
			CZ-RTC5B
Cooling capacity	Nominal (Min - Max)	kW	9,00 (3,00 - 9,70)
EER ¹⁾	Nominal (Min - Max)	W/W	3,47 (5,36 - 3,13) A
SEER ²⁾		W/W	6,50A++
Pdesign		kW	9,00
Input power cooling	Nominal (Min - Max)	kW	2,59 (0,56 - 3,10)
Annual energy consumption ³⁾		kWh/a	485
Heating capacity	Nominal (Min - Max)	kW	9,00 (3,00 - 10,50)
Heating capacity at -7°C / -15°C ⁴⁾		kW	7,92 / —
COP ¹⁾	Nominal (Min - Max)	W/W	3,93 (5,36 - 3,56) A
SCOP ²⁾		W/W	3,90A
Pdesign at -10°C		kW	9,00
Input power heating	Nominal (Min - Max)	kW	2,29 (0,56 - 2,95)
Annual energy consumption ³⁾		kWh/a	3231
Indoor unit			S-100PK2E5B
Air volume	Hi / Med / Lo	m ³ /min	22,00 / 18,50 / 15,00
Moisture removal volume		L/h	4,3
Sound pressure ⁵⁾	Hi / Med / Lo	dB(A)	49 / 45 / 41
Sound power	Hi / Med / Lo	dB	65 / 61 / 57
Dimension	H x W x D	mm	302 x 1120 x 236
Net weight		kg	14
Outdoor unit			U-100PZ2E5
Power source		V	220 / 230 / 240
Recommended fuse		A	—
Connection indoor / outdoor		mm ²	—
Current	Cool	A	12,10 / 11,50 / 11,10
	Heat	A	10,60 / 10,29 / 9,70
Air volume	Cool / Heat	m ³ /min	76 / 70
Sound pressure	Cool / Heat (Hi)	dB(A)	52 / 52
Sound power	Cool / Heat (Hi)	dB	70 / 70
Dimension	H x W x D	mm	996 x 980 x 370
Net weight		kg	90
Piping connections	Liquid pipe	Inch (mm)	3/8 (9,52)
	Gas pipe	Inch (mm)	5/8 (15,88)
Pipe length range		m	5 - 50
Elevation difference (in/out) ⁶⁾		m	30
Pipe length for additional gas		m	30
Additional gas amount		g/m	45
Refrigerant (R32)		kg / TCO ₂ Eq.	2,60 / 1,755
Operating range	Cool Min ~ Max	°C	-10 ~ +43
	Heat Min ~ Max	°C	-15 ~ +24

Accessories

CZ-RTC5B	Wired remote controller with Econavi button and datanavi
CZ-RWSK2	Wireless remote controller
CZ-RE2C2	Simplified remote controller

Accessories

PAW-GRSTD40	Outdoor elevation platform 400 x 900 x 400mm
PAW-WTRAY	Tray for condenser water compatible with base ground support
PAW-GRDBSE20	Outdoor base ground support for noise and vibration absorption

PACi Kits

R32



Optional Controller.
Wired remote controller
CZ-RTCSB
Compatible with Econavi



Optional Controller
Wireless remote controller
CZ-RWSK2



Optional Controller.
Simplified remote controller
CZ-REZC2



Optional Econavi Sensor.
CZ-CENSC1



Closed discharge port.

When the unit is turned OFF, the flap closes completely to prevent dust getting into the unit and to keep the equipment clean.

Quiet operation.

These units are among the quietest in the industry, making them ideal for hotels and hospitals.

Smooth and durable design.

The sleek, compact design ensures a discreet installation - even where space is limited.

Piping outlet in six directions.

Piping outlet is possible in the six directions of right, right rear, right bottom, left, left rear and left bottom, making the installation work easier.

Air distribution is altered depending on the operational mode of the unit.

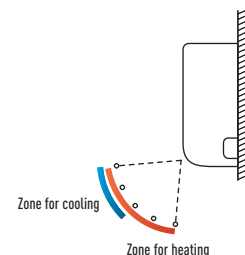

Tentative data			Three Phase
KIT			9,0kW
Remote controller			KIT-100PK2Z8
			CZ-RTCSB
Cooling capacity	Nominal (Min - Max)	kW	9,00 (3,00 - 9,70)
EER ¹⁾	Nominal (Min - Max)	W/W	3,47 (5,36 - 3,13) A
SEER ²⁾		W/W	6,50 A++
Pdesign		kW	9,00
Input power cooling	Nominal (Min - Max)	kW	2,59 (0,56 - 3,10)
Annual energy consumption ³⁾		kWh/a	485
Heating capacity	Nominal (Min - Max)	kW	9,00 (3,00 - 10,50)
Heating capacity at -7°C / -15°C ⁴⁾		kW	7,92 / —
COP ¹⁾	Nominal (Min - Max)	W/W	3,93 (5,36 - 3,56) A
SCOP ²⁾		W/W	3,90 A
Pdesign at -10°C		kW	9,00
Input power heating	Nominal (Min - Max)	kW	2,29 (0,56 - 2,95)
Annual energy consumption ³⁾		kWh/a	3231
Indoor unit			S-100PK2E5B
Air volume	Hi / Med / Lo	m ³ /min	22,00 / 18,50 / 15,00
Moisture removal volume		L/h	4,3
Sound pressure ⁵⁾	Hi / Med / Lo	dB(A)	49 / 45 / 41
Sound power	Hi / Med / Lo	dB	65 / 61 / 57
Dimension	H x W x D	mm	302 x 1120 x 236
Net weight		kg	14
Outdoor unit			U-100PZ2E8
Power source		V	380 / 400 / 415
Recommended fuse		A	—
Connection indoor / outdoor		mm ²	—
Current	Cool	A	4,10 / 3,90 / 3,15
	Heat	A	3,60 / 3,45 / 3,30
Air volume	Cool / Heat	m ³ /min	76 / 70
Sound pressure	Cool / Heat (Hi)	dB(A)	52 / 52
Sound power	Cool / Heat (Hi)	dB	70 / 70
Dimension	H x W x D	mm	996 x 980 x 370
Net weight		kg	90
Piping connections	Liquid pipe	Inch (mm)	3/8 (9,52)
	Gas pipe	Inch (mm)	5/8 (15,88)
Pipe length range		m	5 - 50
Elevation difference (in/out) ⁶⁾		m	30
Pipe length for additional gas		m	30
Additional gas amount		g/m	45
Refrigerant (R32)		kg / TCO: Eq.	2,60 / 1,755
Operating range	Cool Min ~ Max	°C	-10 ~ +43
	Heat Min ~ Max	°C	-15 ~ +24

1) EER and COP calculation is based in accordance to EN14511. 2) For models below 12kW, the SCOP is calculated based on values of EU/626/2011. For models above 12kW, the SCOP is calculated based on values of EU/2281/2016. 3) The annual energy consumption is calculated in accordance to EU/626/2011. 4) Heating capacity is calculated including defrost factor correction. 5) The sound pressure of the units shows the value measured at a position 1m in front of the main body and 1,5 m from the ground. The sound pressure is measured in accordance with Eurovent 6/C/006-97 specification. 6) When installing the outdoor unit at a higher position than the indoor unit.* Recommended fuse for the indoor 3A.



INTERNET CONTROL: Optional.

Compatible with all Panasonic connectivity solutions. For detailed information go to the Control Systems section.

Rating Conditions: Cooling Indoor 27°C DB / 19°C WB. Cooling Outdoor 35°C DB / 24°C WB. Heating Indoor 20°C DB. Heating Outdoor 7°C DB / 6°C WB. (DB: Dry Bulb; WB: Wet Bulb)
Specifications subject to change without notice. For detailed information about ErP, please visit our websites www.aircon.panasonic.eu or www.gtc.panasonic.eu.

NEW PACi STANDARD 4 WAY 90x90 CASSETTE INVERTER+ • R32 GAS

NEW 18



Large capacity PACi. Trusted power and high efficiency.

Thanks to advances in design and technology such as the high performance turbo fan, more efficient and silent, the nanoe™ X air cleaner, the U2 Panasonic 4 way 90x90 cassette offers high energy saving, fresh air and comfort.

Technical focus

- High performance turbo fan, path system for heat exchanger
- Lower noise in slow fan operation
- Light weight, easy piping
- Easy installation structure of the panel
- Econavi: Floor temperature and humidity sensor added. Activity amount detection and new circulator
- nanoe™ X: The first air purifier technology in commercial air conditioning

Tentative data			Single Phase		
			10,0kW	12,5kW	14,0kW
KIT			KIT-100PU2Z5	KIT-125PU2Z5	KIT-140PU2Z5
Remote controller			CZ-RTC5B	CZ-RTC5B	CZ-RTC5B
Cooling capacity	Nominal (Min - Max)	kW	10,00 (3,00 - 11,50)	12,50 (3,20 - 13,50)	14,00 (3,30 - 15,00)
EER ¹⁾	Nominal (Min - Max)	W/W	3,82 (5,36 - 2,88) A	3,58 (5,33 - 2,81) A	3,23 (5,32 - 2,73) A
SEER ²⁾		W/W	6,80 A++	6,75	6,51
P _{design}		kW	10,00	12,50	14,00
Input power cooling	Nominal (Min - Max)	kW	2,62 (0,56 - 4,00)	3,49 (0,60 - 4,80)	4,34 (0,62 - 5,50)
Annual energy consumption ³⁾		kWh/a	515	—	—
Heating capacity	Nominal (Min - Max)	kW	10,00 (3,00 - 14,00)	12,50 (3,30 - 15,00)	14,00 (3,40 - 16,00)
Heating capacity at -7°C / -15°C ⁴⁾		kW	—	—	—
COP ¹⁾	Nominal (Min - Max)	W/W	4,93 (3,59 - 5,36) A	4,43 (3,57 - 5,50) A	4,18 (3,33 - 5,48) A
SCOP ²⁾		W/W	4,40 A+	4,01	3,89
P _{design} at -10°C		kW	10,00	12,50	14,00
Input power heating	Nominal (Min - Max)	kW	2,03 (0,56 - 3,90)	2,82 (0,60 - 4,20)	3,35 (0,62 - 4,80)
Annual energy consumption ³⁾		kWh/a	3182	—	—
Indoor unit			S-100PU2E5B	S-125PU2E5B	S-140PU2E5B
Air volume	Hi / Med / Lo	m ³ /min	36 / 26 / 18	37 / 27 / 19	38 / 29 / 20
Moisture removal volume		L/h	2,7	4,8	6,0
Sound pressure ⁵⁾	Hi / Med / Lo	dB(A)	45 / 38 / 32	46 / 39 / 33	47 / 40 / 34
Sound power	Hi / Med / Lo	dB	60 / 53 / 47	61 / 54 / 48	62 / 55 / 49
Dimension	Indoor (H x W x D)	mm	319 x 840 x 840	319 x 840 x 840	319 x 840 x 840
	Panel (H x W x D)	mm	33,5 x 950 x 950	33,5 x 950 x 950	33,5 x 950 x 950
Net weight	Indoor / Panel	kg	25 / 5	25 / 5	25 / 5
Outdoor unit			U-100P2E5	U-125P2E5	U-140P2E5
Power source		V	220 / 230 / 240	220 / 230 / 240	220 / 230 / 240
Recommended fuse		A	—	—	—
Connection indoor / outdoor		mm ²	—	—	—
Current	Cool	A	12,10 / 11,50 / 11,10	16,30 / 15,60 / 15,00	20,40 / 19,50 / 18,70
	Heat	A	9,25 / 8,85 / 8,50	13,10 / 12,60 / 12,00	15,60 / 15,00 / 14,30
Air volume	Cool / Heat	m ³ /min	76 / 70	86 / 78	89 / 83
Sound pressure	Cool / Heat (Hi)	dB(A)	52 / 52	55 / 55	56 / 56
Sound power	Cool / Heat (Hi)	dB	70 / 70	73 / 73	74 / 74
Dimension	H x W x D	mm	996 x 980 x 370	996 x 980 x 370	996 x 980 x 370
Net weight		kg	90	94	94
Piping connections	Liquid pipe	Inch (mm)	3/8 (9,52)	3/8 (9,52)	3/8 (9,52)
	Gas pipe	Inch (mm)	5/8 (15,88)	5/8 (15,88)	5/8 (15,88)
Pipe length range		m	5 ~ 50	5 ~ 50	5 ~ 50
Elevation difference (in/out) ⁶⁾		m	30	30	30
Pipe length for additional gas		m	30	30	30
Additional gas amount		g/m	45	45	45
Refrigerant (R32)		kg / TCO ₂ Eq.	2,60 / 1,755	2,98 / 2,0115	2,98 / 2,0115
Operating range	Cool Min ~ Max	°C	-10 ~ +43	-10 ~ +43	-10 ~ +43
	Heat Min ~ Max	°C	-15 ~ +24	-15 ~ +24	-15 ~ +24

Accessories	
CZ-RTC5B	Wired remote controller with Econavi button and datanavi
CZ-RWSU3	Wireless remote controller
CZ-RE2C2	Simplified remote controller
CZ-CNEXU1	nanoe™ X air purifying system

Accessories	
CZ-KPU3A	Econavi exclusive panel
PAW-WTRAY	Tray for condenser water compatible with base ground support
PAW-GRDBSE20	Outdoor base ground support for noise and vibration absorption

PACi Kits

R32



Optional Controller. Wired remote controller CZ-RTCSB
Compatible with Econavi and nanoE™ X
Optional Controller. Wireless remote control CZ-RWSU3
Optional Controller. Simplified remote controller CZ-REZC2
Econavi panel: CZ-KPU3A (CZ-RTCSB is required)
Optional nanoE™ X kit: CZ-CNEXU1 (CZ-RTCSB is required)



Group control, new circulation function

Do circulating operation when nobody there, and mix air in the whole room. Minimize temperature gap in both heating and cooling operation.

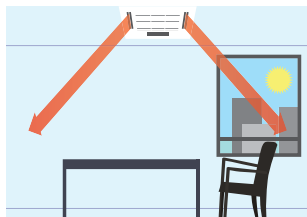

Circulation by Detecting no movement (10min.)



Indirect air flow by detecting movement

2 types of body with height difference (same as current ones)

25,6cm and 31,9cm.

Always fresh and clean air with nanoE™ X

nanoE™ X is newly developed for PACi cassette by the advanced technology of Room Air conditioning.



CZ-RTCSB and optional accessory CZ-CNEXU1 are required to use nanoE™ X function.

Tentative data

			Three Phase		
			10,0kW	12,5kW	14,0kW
KIT			KIT-100PU2Z8	KIT-125PU2Z8	KIT-140PU2Z8
Remote controller			CZ-RTCSB	CZ-RTCSB	CZ-RTCSB
Cooling capacity	Nominal (Min - Max)	kW	10,00 (3,00 - 11,50)	12,50 (3,20 - 13,50)	14,00 (3,30 - 15,00)
EER ¹⁾	Nominal (Min - Max)	W/W	3,82 (5,36 - 2,88) A	3,58 (5,33 - 2,81) A	3,23 (5,32 - 2,73) A
SEER ²⁾		W/W	6,70 A++	6,73	6,49
Pdesign		kW	10,00	12,50	14,00
Input power cooling	Nominal (Min - Max)	kW	2,62 (0,56 - 4,00)	3,49 (0,60 - 4,80)	4,34 (0,62 - 5,50)
Annual energy consumption ³⁾		kWh/a	521	—	—
Heating capacity	Nominal (Min - Max)	kW	10,00 (3,00 - 14,00)	12,50 (3,30 - 15,00)	14,00 (3,40 - 16,00)
Heating capacity at -7°C / -15°C ⁴⁾		kW	—	—	—
COP ¹⁾	Nominal (Min - Max)	W/W	4,93 (3,59 - 5,36) A	4,43 (3,57 - 5,50) A	4,18 (3,33 - 5,48) A
SCOP ²⁾		W/W	4,40 A+	4,01	3,89
Pdesign at -10°C		kW	10,00	12,50	14,00
Input power heating	Nominal (Min - Max)	kW	2,03 (0,56 - 3,90)	2,82 (0,60 - 4,20)	3,35 (0,62 - 4,80)
Annual energy consumption ³⁾		kWh/a	3182	—	—
Indoor unit			S-100PU2E5B	S-125PU2E5B	S-140PU2E5B
Air volume	Hi / Med / Lo	m ³ /min	36/26/18	37/27/19	38/29/20
Moisture removal volume		L/h	2,7	4,8	6,0
Sound pressure ⁵⁾	Hi / Med / Lo	dB(A)	45/38/32	46/39/33	47/40/34
Sound power	Hi / Med / Lo	dB	60/53/47	61/54/48	62/55/49
Dimension	Indoor (H x W x D)	mm	319 x 840 x 840	319 x 840 x 840	319 x 840 x 840
	Panel (H x W x D)	mm	33,5 x 950 x 950	33,5 x 950 x 950	33,5 x 950 x 950
Net weight	Indoor / Panel	kg	25/5	25/5	25/5
Outdoor unit			U-100PZ2E8	U-125PZ2E8	U-140PZ2E8
Power source		V	380/400/415	380/400/415	380/400/415
Recommended fuse		A	—	—	—
Connection indoor / outdoor		mm ²	—	—	—
Current	Cool	A	4,10/3,90/3,75	5,45/5,20/5,00	6,85/6,50/6,25
	Heat	A	3,15/3,00/2,90	4,40/4,15/4,00	5,25/4,95/4,80
Air volume	Cool / Heat	m ³ /min	76/70	86/78	89/83
Sound pressure	Cool / Heat (Hi)	dB(A)	52/52	55/55	56/56
Sound power	Cool / Heat (Hi)	dB	70/70	73/73	74/74
Dimension	H x W x D	mm	996 x 980 x 370	996 x 980 x 370	996 x 980 x 370
Net weight		kg	90	94	94
Piping connections	Liquid pipe	Inch (mm)	3/8 (9,52)	3/8 (9,52)	3/8 (9,52)
	Gas pipe	Inch (mm)	5/8 (15,88)	5/8 (15,88)	5/8 (15,88)
Pipe length range		m	5 - 50	5 - 50	5 - 50
Elevation difference (in/out) ⁶⁾		m	30	30	30
Pipe length for additional gas		m	30	30	30
Additional gas amount		g/m	45	45	45
Refrigerant (R32)		kg/TCO: Eq.	2,60/1,755	2,98/2,0115	2,98/2,0115
Operating range	Cool Min ~ Max	°C	-10 ~ +43	-10 ~ +43	-10 ~ +43
	Heat Min ~ Max	°C	-15 ~ +24	-15 ~ +24	-15 ~ +24

1) EER and COP calculation is based in accordance to EN14511. 2) For models below 12kW, the SCOP is calculated based on values of EU/626/2011. For models above 12kW, the SCOP is calculated based on values of EU/2281/2016. 3) The annual energy consumption is calculated in accordance to EU/626/2011. 4) Heating capacity is calculated including defrost factor correction. 5) The sound pressure of the units shows the value measured of a position 1m in front of the main body and 1,5 m from the ground. The sound pressure is measured in accordance with Eurovent 6/C/006-97 specification. 6) When installing the outdoor unit at a higher position than the indoor unit. * Recommended fuse for the indoor 3A.



SEER and SCOP: For KIT-100PU2Z5, ECONAVI and INTERNET CONTROL: Optional.
Compatible with all Panasonic connectivity solutions. For detailed information go to the Control Systems section.

Rating Conditions: Cooling Indoor 27°C DB / 19°C WB. Cooling Outdoor 35°C DB / 24°C WB. Heating Indoor 20°C DB. Heating Outdoor 7°C DB / 6°C WB. (DB: Dry Bulb; WB: Wet Bulb)
Specifications subject to change without notice. For detailed information about ErP, please visit our websites www.aircon.panasonic.eu or www.gtc.panasonic.eu.

NEW PACi STANDARD CEILING INVERTER+

• R32 GAS

NEW
18



This range of ceiling mounted units feature a DC fan motor for increased efficiency and reduced operating sound levels.

All the units are the same height and depth for a uniform appearance in mixed installations. A knock out is provided to allow for supplementary fresh air for improved air quality.

- Twin rotary compressor dramatically reduces vibration and noise
- DC inverter control
- Large and wide air distribution
- Industry-leading low sound levels
- Twin, Triple and Double-twin split options
- Easy connection and control of external fan or ERV using the connector PAW-FDC on the indoor unit PCB. The external device can be control by the remote control of the Panasonic indoor unit

Technical focus

- Fresh air connection possible (Outside intake duct connection port of 100mm diameter is available on the unit)
- All units just 235mm high

High heating capacity at -7°C.

Tentative data			Single Phase		
			10,0kW	12,5kW	14,0kW
KIT			KIT-100PT2Z5	KIT-125PT2Z5	KIT-140PT2Z5
Remote controller			CZ-RTC5B	CZ-RTC5B	CZ-RTC5B
Cooling capacity	Nominal (Min - Max)	kW	10,00 (3,00 - 11,50)	12,50 (3,20 - 13,50)	14,00 (3,30 - 15,00)
EER ¹⁾	Nominal (Min - Max)	W/W	3,64 (5,36 - 2,80) A	3,32 (5,33 - 2,77) A	2,98 (5,32 - 2,73) C
SEER ²⁾		W/W	6,50 A++	5,77	5,49
Pdesign		kW	10,00	12,50	14,00
Input power cooling	Nominal (Min - Max)	kW	2,75 (0,56 - 4,10)	3,76 (0,60 - 4,88)	4,70 (0,62 - 5,50)
Annual energy consumption ³⁾		kWh/a	535	1300	1530
Heating capacity	Nominal (Min - Max)	kW	10,00 (3,00 - 14,00)	12,50 (3,30 - 15,00)	14,00 (3,40 - 16,00)
Heating capacity at -7°C / -15°C ⁴⁾		kW	8,85 / 6,40	11,00 / 8,00	12,00 / 8,40
COP ¹⁾	Nominal (Min - Max)	W/W	4,24 (5,36 - 3,50) A	3,89 (4,52 - 3,41) A	3,70 (5,48 - 3,08) A
SCOP ²⁾		W/W	4,20 A+	3,75	3,70
Pdesign at -10°C		kW	10,00	12,50	13,60
Input power heating	Nominal (Min - Max)	kW	2,36 (0,56 - 4,00)	3,21 (0,73 - 4,40)	3,78 (0,62 - 5,20)
Annual energy consumption ³⁾		kWh/a	3324	4669	5153
Indoor unit			S-100PT2E5B	S-125PT2E5B	S-140PT2E5B
Air volume	Hi / Med / Lo	m ³ /min	30 / 25 / 23	34 / 28 / 24	35 / 29 / 25
Moisture removal volume		L/h	6,0	7,9	9,0
Sound pressure ⁵⁾	Hi / Med / Lo	dB(A)	42 / 37 / 35	46 / 40 / 36	47 / 41 / 37
Sound power	Hi / Med / Lo	dB	60 / 55 / 53	64 / 58 / 54	65 / 59 / 55
Dimension	H x W x D	mm	235 x 1590 x 690	235 x 1590 x 690	235 x 1590 x 690
Net weight		kg	40	40	40
Outdoor unit			U-100PZ2E5	U-125PZ2E5	U-140PZ2E5
Power source		V	220 / 230 / 240	220 / 230 / 240	220 / 230 / 240
Recommended fuse		A	—	—	—
Connection indoor / outdoor		mm ²	—	—	—
Current	Cool	A	12,80 / 12,20 / 11,70	17,60 / 16,90 / 16,20	22,10 / 21,20 / 20,30
	Heat	A	10,90 / 10,40 / 10,00	15,00 / 14,30 / 13,70	17,70 / 16,90 / 16,20
Air volume	Cool / Heat	m ³ /min	76 / 70	86 / 78	89 / 83
Sound pressure	Cool / Heat (Hi)	dB(A)	52 / 52	55 / 55	56 / 56
Sound power	Cool / Heat (Hi)	dB	70 / 70	73 / 73	74 / 74
Dimension	H x W x D	mm	996 x 980 x 370	996 x 980 x 370	996 x 980 x 370
Net weight		kg	90	94	94
Piping connections	Liquid pipe	Inch (mm)	3/8 (9,52)	3/8 (9,52)	3/8 (9,52)
	Gas pipe	Inch (mm)	5/8 (15,88)	5/8 (15,88)	5/8 (15,88)
Pipe length range		m	5 - 50	5 - 50	5 - 50
Elevation difference (in/out) ⁶⁾		m	30	30	30
Pipe length for additional gas		m	30	30	30
Additional gas amount		g/m	45	45	45
Refrigerant (R32)		kg / TCO ₂ Eq.	2,60 / 1,755	2,98 / 2,0115	2,98 / 2,0115
Operating range	Cool Min ~ Max	°C	-10 ~ +43	-10 ~ +43	-10 ~ +43
	Heat Min ~ Max	°C	-15 ~ +24	-15 ~ +24	-15 ~ +24

Accessories

CZ-RTC5B	Wired remote controller with Econavi button and datanavi
CZ-RWST3N	Wireless remote controller
CZ-RE2C2	Simplified remote controller

Accessories

PAW-WTRAY	Tray for condenser water compatible with base ground support
PAW-GRDBSE20	Outdoor base ground support for noise and vibration absorption
PAW-GRDSTD40	Outdoor elevation platform 400 x 900 x 400mm

PACi Kits

R32



Optional Controller. Wired remote controller CZ-RTCSB
Compatible with Econavi



Optional Controller. Wireless remote controller CZ-RWST3N



Optional Controller. Simplified remote controller CZ-REZC2



Optional Econavi Sensor CZ-CENSC1



Further comfort improvement

The wide air discharge opening expands the air flow to the left and the right. The unpleasant feeling caused when the air flow directly hits the human body is prevented by the "Draft prevention position", which changes the swing width, so that the degree of comfort is increased.

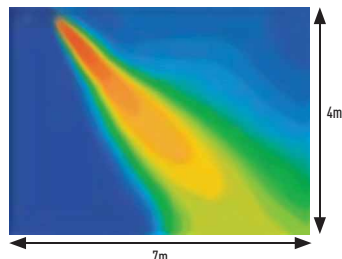

Further comfort improvement with airflow distribution

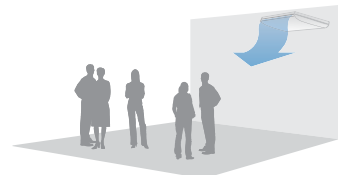

Air distribution is altered depending on the operational mode of the unit

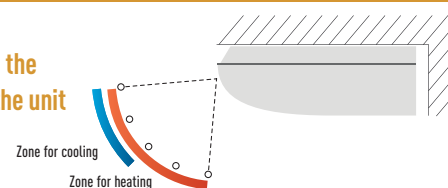

Tentative data			Three Phase		
			10,0kW	12,5kW	14,0kW
KIT			KIT-100PT2Z8	KIT-125PT2Z8	KIT-140PT2Z8
Remote controller			CZ-RTCSB	CZ-RTCSB	CZ-RTCSB
Cooling capacity	Nominal (Min - Max)	kW	10,00 (3,00 - 11,50)	12,50 (3,20 - 13,50)	14,00 (3,30 - 15,00)
EER ¹⁾	Nominal (Min - Max)	W/W	3,64 (5,36 - 2,80) A	3,32 (5,33 - 2,77) A	2,98 (5,32 - 2,73) C
SEER ²⁾		W/W	6,50 A++	5,75	5,48
Pdesign		kW	10,00	12,50	14,00
Input power cooling	Nominal (Min - Max)	kW	2,75 (0,56 - 4,10)	3,76 (0,60 - 4,88)	4,70 (0,62 - 5,50)
Annual energy consumption ³⁾		kWh/a	538	1304	1534
Heating capacity	Nominal (Min - Max)	kW	10,00 (3,00 - 14,00)	12,50 (3,30 - 15,00)	14,00 (3,40 - 16,00)
Heating capacity at -7°C / -15°C ⁴⁾		kW	8,85 / 6,40	11,00 / 8,00	12,00 / 8,40
COP ¹⁾	Nominal (Min - Max)	W/W	4,24 (5,36 - 3,50) A	3,89 (4,52 - 3,41) A	3,70 (5,48 - 3,08) A
SCOP ²⁾		W/W	4,20 A+	3,75	3,70
Pdesign at -10°C		kW	10,00	12,50	13,60
Input power heating	Nominal (Min - Max)	kW	2,36 (0,56 - 4,00)	3,21 (0,73 - 4,40)	3,78 (0,62 - 5,20)
Annual energy consumption ³⁾		kWh/a	3324	4669	5153
Indoor unit			S-100PT2E5B	S-125PT2E5B	S-140PT2E5B
Air volume	Hi / Med / Lo	m ³ /min	30/25/23	34/28/24	35/29/25
Moisture removal volume		L/h	6,0	7,9	9,0
Sound pressure ⁵⁾	Hi / Med / Lo	dB(A)	42/37/35	46/40/36	47/41/37
Sound power	Hi / Med / Lo	dB	60/55/53	64/58/54	65/59/55
Dimension	H x W x D	mm	235 x 1590 x 690	235 x 1590 x 690	235 x 1590 x 690
Net weight		kg	40	40	40
Outdoor unit			U-100PZ2E8	U-125PZ2E8	U-140PZ2E8
Power source		V	380/400/415	380/400/415	380/400/415
Recommended fuse		A	—	—	—
Connection indoor / outdoor		mm ²	—	—	—
Current	Cool	A	4,37/4,15/4,00	5,90/5,60/5,40	7,40/7,05/6,80
	Heat	A	3,72/3,55/3,40	5,00/4,75/4,60	5,90/5,60/5,40
Air volume	Cool / Heat	m ³ /min	76/70	86/78	89/83
Sound pressure	Cool / Heat (Hi)	dB(A)	52/52	55/55	56/56
Sound power	Cool / Heat (Hi)	dB	70/70	73/73	74/74
Dimension	H x W x D	mm	996 x 980 x 370	996 x 980 x 370	996 x 980 x 370
Net weight		kg	90	94	94
Piping connections	Liquid pipe	Inch (mm)	3/8 (9,52)	3/8 (9,52)	3/8 (9,52)
	Gas pipe	Inch (mm)	5/8 (15,88)	5/8 (15,88)	5/8 (15,88)
Pipe length range		m	5 - 50	5 - 50	5 - 50
Elevation difference (in/out) ⁶⁾		m	30	30	30
Pipe length for additional gas		m	30	30	30
Additional gas amount		g/m	45	45	45
Refrigerant (R32)		kg/TCO: Eq.	2,60/1,755	2,98/2,0115	2,98/2,0115
Operating range	Cool Min ~ Max	°C	-10 ~ +43	-10 ~ +43	-10 ~ +43
	Heat Min ~ Max	°C	-15 ~ +24	-15 ~ +24	-15 ~ +24

1) EER and COP calculation is based in accordance to EN14511. 2) For models below 12kW, the SCOP is calculated based on values of EU/626/2011. For models above 12kW, the SCOP is calculated based on values of EU/2281/2016. 3) The annual energy consumption is calculated in accordance to EU/626/2011. 4) Heating capacity is calculated including defrost factor correction. 5) The sound pressure of the units shows the value measured at a position 1m in front of the main body and 1,5 m from the ground. The sound pressure is measured in accordance with Eurovent 6/C/006-97 specification. 6) When installing the outdoor unit at a higher position than the indoor unit.* Recommended fuse for the indoor 3A.



SEER and SCOP: For KIT-100PT2Z5 and KIT-100PT2Z8. INTERNET CONTROL: Optional.
Compatible with all Panasonic connectivity solutions. For detailed information go to the Control Systems section.

Rating Conditions: Cooling Indoor 27°C DB / 19°C WB. Cooling Outdoor 35°C DB / 24°C WB. Heating Indoor 20°C DB. Heating Outdoor 7°C DB / 6°C WB. (DB: Dry Bulb; WB: Wet Bulb)
Specifications subject to change without notice. For detailed information about ErP, please visit our websites www.aircon.panasonic.eu or www.gtc.panasonic.eu.

NEW PACi STANDARD HIGH STATIC PRESSURE HIDE AWAY INVERTER+ • R32 GAS



NEW
18

The ducted systems are the ideal solution for flexible, concealed air conditioning and the optional 200mm spigots ensure simple, hassle-free connection to spiral ductwork.

High heating capacity at -7°C.

Technical focus

- Auto restart after power failure
- Auto changeover
- Twin split options
- DC FAN for better efficiency and control
- Built in drain pump
- Easy connection and control of external fan or ERV using the connector PAW-FDC on the indoor unit PCB. The external device can be control by the remote control of the Panasonic indoor unit

Tentative data			Single Phase			
			10,0kW	12,5kW	14,0kW	
KIT			KIT-100PF1Z5	KIT-125PF1Z5	KIT-140PF1Z5	
Remote controller			CZ-RTC5B	CZ-RTC5B	CZ-RTC5B	
Cooling capacity	Nominal (Min - Max)	kW	10,00 (3,00 - 11,50)	12,50 (3,20 - 13,50)	14,00 (3,30 - 15,00)	
EER ¹⁾	Nominal (Min - Max)	W/W	3,66 (5,36 - 2,81) A	3,52 (5,33 - 2,80) A	3,18 (5,32 - 2,70) B	
SEER ²⁾		W/W	5,60 A+	5,56	5,38	
Pdesign		kW	10,00	12,50	14,00	
Input power cooling	Nominal (Min - Max)	kW	2,73 (0,56 - 4,09)	3,55 (0,60 - 4,82)	4,40 (0,62 - 5,56)	
Annual energy consumption ³⁾		kWh/a	625	787	911	
Heating capacity	Nominal (Min - Max)	kW	10,00 (3,00 - 14,00)	12,50 (3,30 - 15,00)	14,00 (3,40 - 16,00)	
Heating capacity at -7°C / -15°C ⁴⁾		kW	— / —	11,00 / —	12,00 / —	
COP ¹⁾	Nominal (Min - Max)	W/W	4,31 (5,36 - 3,51) A	4,02 (5,50 - 3,45) A	3,79 (5,48 - 3,13) A	
SCOP ²⁾		W/W	3,80 A	3,61	3,54	
Pdesign at -10°C		kW	10,00	12,50	13,60	
Input power heating	Nominal (Min - Max)	kW	2,32 (0,56 - 3,99)	3,11 (0,60 - 4,35)	3,69 (0,62 - 5,12)	
Annual energy consumption ³⁾		kWh/a	3684	4848	5379	
Indoor unit			S-100PF1E5B	S-125PF1E5B	S-140PF1E5B	
External static pressure ⁵⁾	Nominal (Min - Max)	Pa	100 (10 - 150)	100 (10 - 150)	100 (10 - 150)	
Air volume	Hi / Med / Lo	m ³ /min	32/26/21	34/29/23	36/32/25	
Moisture removal volume		L/h	6,0	7,9	9,0	
Sound pressure ⁶⁾	Hi / Med / Lo	dB(A)	38/34/31	39/35/32	40/36/33	
Sound power	Hi / Med / Lo	dB	60/56/53	61/57/54	62/58/55	
Dimension	H x W x D	mm	290 x 1400 x 700	290 x 1400 x 700	290 x 1400 x 700	
Net weight		kg	45	45	45	
Outdoor unit			U-100PZ2E5	U-125PZ2E5	U-140PZ2E5	
Power source		V	220/230/240	220/230/240	220/230/240	
Recommended fuse		A	—	—	—	
Connection indoor / outdoor		mm ²	—	—	—	
Current	Cool	A	12,10/11,60/11,10	16,10/15,50/14,80	20,20/19,30/18,60	
	Heat	A	10,10/9,70/9,30	14,00/13,40/12,90	16,80/16,00/15,30	
Air volume	Cool / Heat	m ³ /min	76/70	86/78	89/83	
Sound pressure	Cool / Heat (Hi)	dB(A)	52/52	55/55	56/56	
Sound power	Cool / Heat (Hi)	dB	70/70	73/73	74/74	
Dimension	H x W x D	mm	996 x 980 x 370	996 x 980 x 370	996 x 980 x 370	
Net weight		kg	90	94	94	
Piping connections	Liquid pipe	Inch (mm)	3/8 (9,52)	3/8 (9,52)	3/8 (9,52)	
	Gas pipe	Inch (mm)	5/8 (15,88)	5/8 (15,88)	5/8 (15,88)	
Pipe length range		m	5 ~ 50	5 ~ 50	5 ~ 50	
Elevation difference (in/out) ⁷⁾		m	30	30	30	
Pipe length for additional gas		m	30	30	30	
Additional gas amount		g/m	45	45	45	
Refrigerant (R32)		kg / TCO: Eq.	2,60 / 1,755	2,98 / 2,0115	2,98 / 2,0115	
Operating range	Cool Min ~ Max	°C	-10 ~ +43	-10 ~ +43	-10 ~ +43	
	Heat Min ~ Max	°C	-15 ~ +24	-15 ~ +24	-15 ~ +24	

Accessories

CZ-RTC5B	Wired remote controller with Econavi button and datanavi
CZ-RWSK2 + CZ-RWSC3	Wireless remote controller
CZ-RE2C2	Simplified remote controller
PAW-WTRAY	Tray for condenser water compatible with base ground support
PAW-GRDBSE20	Outdoor base ground support for noise and vibration absorption
PAW-GRDSTD40	Outdoor elevation platform 400 x 900 x 400mm

Accessories

CZ-56DAF2	Air Outlet Plenum S . .PF1E5B 36, 45 & 50
CZ-90DAF2	Air Outlet Plenum S . .PF1E5B 60 & 71
CZ-160DAF2	Air Outlet Plenum S . .PF1E5B 100, 125 & 140
CZ-DUMPA90MF2	Air Inlet Plenum S . .PF1E5B 60 & 71
CZ-DUMPA160MF2	Air Inlet Plenum S . .PF1E5B 100, 125 & 140

PACi Kits

R32



Optional Controller. Wired remote controller CZ-RTCSB Compatible with Econavi
 Optional Controller. Wireless remote controller CZ-RWSK2 + CZ-RWSC3
 Optional Controller. Simplified remote controller CZ-REZC2
 Optional Econavi Sensor. CZ-CENSC1



Air Outlet Plenum (without regulation adaptor)

Diameters	Model
36, 45 & 50	2xØ 200 CZ-56DAF2
60 & 71	3xØ 200 CZ-90DAF2
100, 125 & 140	4xØ 200 CZ-160DAF2

Air Inlet Plenum

Diameters	Model
60 & 71	2xØ 250 CZ-DUMPA90MF2
100, 125 & 140	4xØ 200 CZ-DUMPA160MF2

Standardized height of 290mm for all models. Height standardization enables easy and uniform installation for models with different capacities.

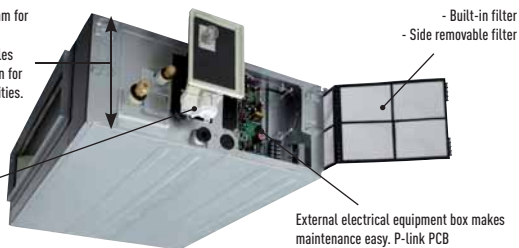

Built-in Drain pump (DC motor pump)

External electrical equipment box makes maintenance easy. P-link PCB

The static pressure outside the unit can be increased up to 150 Pa

Type		36	45	50	60	71	100	125	140
Standard	Pa	70	70	70	70	70	100	100	100
Maximum available setting	Pa	150	150	150	150	150	150	150	150

More powerful drain pump

Using a high-lift drain pump, drain piping can be elevated up to 785mm from the base of the unit.

Tentative data

			Three Phase		
			10,0kW	12,5kW	14,0kW
KIT			KIT-100PF1Z8	KIT-125PF1Z8	KIT-140PF1Z8
Remote controller			CZ-RTCSB	CZ-RTCSB	CZ-RTCSB
Cooling capacity	Nominal (Min - Max)	kW	10,00 (3,00 - 11,50)	12,50 (3,20 - 13,50)	14,00 (3,30 - 15,00)
EER ¹⁾	Nominal (Min - Max)	W/W	3,66 (5,36 - 2,81) A	3,52 (5,33 - 2,80) A	3,18 (5,32 - 2,70) B
SEER ²⁾		W/W	5,60 A+	5,54	5,37
Pdesign		kW	10,00	12,50	14,00
Input power cooling	Nominal (Min - Max)	kW	2,73 (0,56 - 4,09)	3,55 (0,60 - 4,82)	4,40 (0,62 - 5,56)
Annual energy consumption ³⁾		kWh/a	625	790	912
Heating capacity	Nominal (Min - Max)	kW	10,00 (3,00 - 14,00)	12,50 (3,30 - 15,00)	14,00 (3,40 - 16,00)
Heating capacity at -7°C / -15°C ⁴⁾		kW	— / —	11,00 / —	12,00 / —
COP ¹⁾	Nominal (Min - Max)	W/W	4,31 (5,36 - 3,51) A	4,02 (5,50 - 3,45) A	3,79 (5,48 - 3,13) A
SCOP ²⁾		W/W	3,80 A	3,61	3,54
Pdesign at -10°C		kW	10,00	12,50	13,60
Input power heating	Nominal (Min - Max)	kW	2,32 (0,56 - 3,99)	3,11 (0,60 - 4,35)	3,69 (0,62 - 5,12)
Annual energy consumption ³⁾		kWh/a	3684	4848	5379
Indoor unit			S-100PF1E5B	S-125PF1E5B	S-140PF1E5B
External static pressure ⁵⁾	Nominal (Min - Max)	Pa	100 (10 - 150)	100 (10 - 150)	100 (10 - 150)
Air volume	Hi / Med / Lo	m ³ /min	32/26/21	34/29/23	36/32/25
Moisture removal volume		L/h	6,0	7,9	9,0
Sound pressure ⁶⁾	Hi / Med / Lo	dB(A)	38/34/31	39/35/32	40/36/33
Sound power	Hi / Med / Lo	dB	60/56/53	61/57/54	62/58/55
Dimension	H x W x D	mm	290 x 1400 x 700	290 x 1400 x 700	290 x 1400 x 700
Net weight		kg	45	45	45
Outdoor unit			U-100PZ2E8	U-125PZ2E8	U-140PZ2E8
Power source		V	380/400/415	380/400/415	380/400/415
Recommended fuse		A	—	—	—
Connection indoor / outdoor		mm ²	—	—	—
Current	Cool	A	4,15/3,95/3,80	5,40/5,10/4,95	6,75/6,40/6,15
	Heat	A	3,45/3,30/3,20	4,70/4,45/4,30	5,60/5,30/5,15
Air volume	Cool / Heat	m ³ /min	76/70	86/78	89/83
Sound pressure	Cool / Heat (Hi)	dB(A)	52/52	55/55	56/56
Sound power	Cool / Heat (Hi)	dB	70/70	73/73	74/74
Dimension	H x W x D	mm	996 x 980 x 370	996 x 980 x 370	996 x 980 x 370
Net weight		kg	90	94	94
Piping connections	Liquid pipe	Inch (mm)	3/8 (9,52)	3/8 (9,52)	3/8 (9,52)
	Gas pipe	Inch (mm)	5/8 (15,88)	5/8 (15,88)	5/8 (15,88)
Pipe length range		m	5 - 50	5 - 50	5 - 50
Elevation difference (in/out) ⁷⁾		m	30	30	30
Pipe length for additional gas		m	30	30	30
Additional gas amount		g/m	45	45	45
Refrigerant (R32)		kg/TCO: Eq.	2,60 / 1,755	2,98 / 2,0115	2,98 / 2,0115
Operating range	Cool Min ~ Max	°C	-10 ~ +43	-10 ~ +43	-10 ~ +43
	Heat Min ~ Max	°C	-15 ~ +24	-15 ~ +24	-15 ~ +24















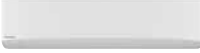
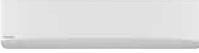
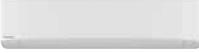
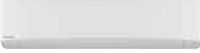















1) EER and COP calculation is based in accordance to EN14511. 2) For models below 12kW, the SCOP is calculated based on values of EU/626/2011. For models above 12kW, the SCOP is calculated based on values of EU/2281/2016. 3) The annual energy consumption is calculated in accordance to EU/626/2011. 4) Heating capacity is calculated including defrost factor correction. At -10°C only for 10,0kW. 5) Medium External static pressure setting from factory. 6) The sound pressure of the units shows the value measured of a position 1m in front of the main body and 1,5 m from the ground. The sound pressure is measured in accordance with Eurovent 6/C/006-97 specification. 7) When installing the outdoor unit at a higher position than the indoor unit. * Recommended fuse for the indoor 3A.







SEER and SCOP: For KIT-100PF1Z5 and KIT-100PF1Z8. INTERNET CONTROL: Optional. Compatible with all Panasonic connectivity solutions. For detailed information go to the Control Systems section.

Rating Conditions: Cooling Indoor 27°C DB / 19°C WB. Cooling Outdoor 35°C DB / 24°C WB. Heating Indoor 20°C DB. Heating Outdoor 7°C DB / 6°C WB. (DB: Dry Bulb; WB: Wet Bulb) Specifications subject to change without notice. For detailed information about ErP, please visit our websites www.aircon.panasonic.eu or www.gtc.panasonic.eu.

RANGE OF COMMERCIAL UNITS R410A

Page	Indoor Units	2,5kW	3,5 ~ 3,6kW	4,2 ~ 4,5kW	5,0kW	6,0kW
P. 182	Wall Mounted Professional Inverter -20°C • R410A GAS	 KIT-E9-PKEA	 KIT-E12-PKEA	 KIT-E15-PKEA	 KIT-E18-PKEA	
P. 184	NEW Wall Inverter+ • R410A GAS		 S-36PK2E5B	 S-45PK2E5B	 S-50PK2E5B	 S-60PK2E5B
Check it in RAC part	4-Way 60x60 Cassette Inverter • R410A GAS	 KIT-E9-PB4EA	 KIT-E12-PB4EA		 KIT-E18-RB4EA	 KIT-E21-RB4EA
P. 188	4 Way 60x60 Cassette Inverter+ • R410A GAS		 S-36PY2E5A	 S-45PY2E5A	 S-50PY2E5A	
P. 190	4 Way 90x90 Cassette Inverter+ • R410A GAS		 S-36PU2E5B	 S-45PU2E5B	 S-50PU2E5B	 S-60PU2E5B
P. 194	Ceiling Inverter+ • R410A GAS		 S-36PT2E5B	 S-45PT2E5B	 S-50PT2E5B	 S-60PT2E5B
Check it in RAC part	Low Static Pressure Hide Away Inverter • R410A GAS	 KIT-E9-PD3EA	 KIT-E12-QD3EA		 KIT-E18-RD3EA	
P. 198	High Static Pressure Hide Away Inverter+ • R410A GAS		 S-36PF1E5B	 S-45PF1E5B	 S-50PF1E5B	 S-60PF1E5B
P. 202	Low Static Pressure Hide Away Inverter+ • R410A GAS		 S-36PN1E5A	 S-45PN1E5A	 S-50PN1E5A	 S-60PN1E5A
P. 206	High Static Pressure Hide Away 20-25kW Inverter+ • R410A GAS					

Outdoor Units PACi Elite and Standard	3,6kW	5,0kW	6,0kW
PACi Elite	 U-36PE2E5A	 U-50PE2E5A	 U-60PE2E5A
PACi Standard			 U-60PEY2E5

U-__E5A Single Phase / U-__E8A Three Phase. 1) The indoor units from 3,6 to 4,5kW are only available only for Twin, Triple and Doble-Twin combinations.

PACi Kits

R410A

7,1kW

10,0kW

12,5kW

14,0kW

20,0kW

25,0kW

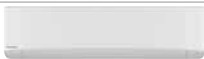
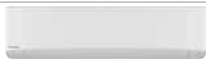

S-71PK2E5B

S-100PK2E5B (9,0kW)



S-71PU2E5B

S-100PU2E5B

S-125PU2E5B

S-140PU2E5B



S-71PT2E5B

S-100PT2E5B

S-125PT2E5B

S-140PT2E5B



S-71PF1E5B

S-100PF1E5B

S-125PF1E5B

S-140PF1E5B



S-71PN1E5A

S-100PN1E5A

S-125PN1E5A

S-140PN1E5A



S-200PE2E5

S-250PE2E5

7,1kW

10,0kW

12,5kW

14,0kW

20,0kW

25,0kW



U-71PE1E5A / U-71PE1E8A

U-100PE1E5A / U-100PE1E8A

U-125PE1E5A / U-125PE1E8A

U-140PE1E5A / U-140PE1E8A

U-200PE2E8A

U-250PE2E8A



U-71PEY2E5

U-100PEY1E5 / U-100PEY1E8

U-125PEY1E5 / U-125PEY1E8

U-140PEY1E8

WALL MOUNTED PROFESSIONAL INVERTER

-20°C • R410A GAS

Complete line-up with high efficiency even at -20°C

High durability for 24/7 operation

Indoor Fan. Cross-Flow-Fan.

- High durability rolling bearings, large size (φ105mm) fan
- High efficiency blade
- Random pitch blade (low sound)

Compressor.

DC2P Panasonic original compressor, with high efficiency and reliability.

Why is the Panasonic R2 Rotary Compressor so efficient?

1. High efficiency motor: the premium silicon steel motor meets industry efficiency requirements
2. Improved lubrication of high volume oil pump: the extended, high volume oil pump in conjunction with a larger capacity oil reservoir provides superior lubrication
3. Accumulator has larger refrigerant capacity: the larger accumulator accommodates generous refrigerant amounts needed in longer line length installations



PKEA provides high capacity at -20°C!

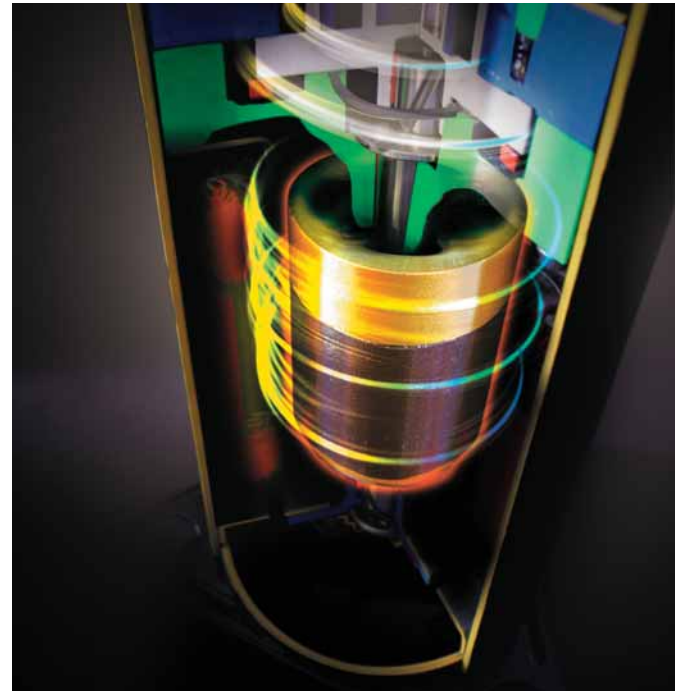
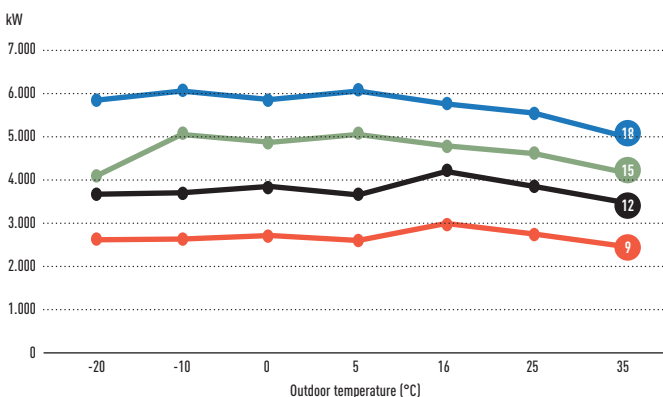

Interface option to manage server room operation

The PAW-SERVER-PKEA server room interface manages redundancy and backup of two PKEA units with two different selectable modes:

- Plug and play by embedded redundancy and backup algorithm (no external signal needed. Further details please refer to operation manual)
- External (third party PLC) redundancy and backup management by dry contact

All settings are possible without the need for a computer connection. A special Energy Saving Mode is selectable by deep switch (available only in plug and play mode). The level of remote control input prohibition can be set when external management is by dry contact.

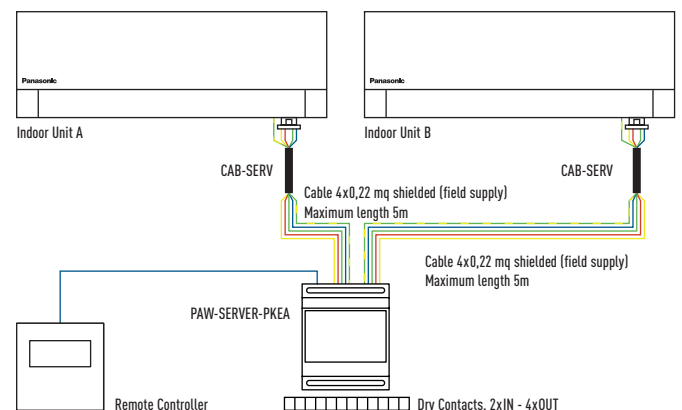

Main Features

- Cascade management
- Back Up system
- Overheating prevention

- ECO function
- BMS management available

Only available

- CS.ZXXTKEA
- CS.EXXQKE / PKE / NKE

Splits 1x1

R410A



This Wall Mounted air conditioner is especially designed for professional applications such as computer rooms where cooling inside the room is necessary even when the outside temperature is low. Furthermore this air conditioner has an automatic changeover system, in order to maintain the inside temperature even when sharp outside temperature changes occur.

- High durability rolling bearings
- Additional piping sensors to prevent freezing

Technical focus

- This units can be installed on R22 pipings
- Designed for 24h/7d a week operation
- Highly efficient even at -20°C

Outdoor Features

- Cooling even when ambient temperature is as low as -20°C
- Electronic expansion valve (accurate sub-cooling and adjustable refrigerant flow)
- Outdoor DC fan motor to provide flexible air-flow to ensure optimum condensation pressure (works on outdoor pipe temperature sensor)

KIT			KIT-E9-PKEA	KIT-E12-PKEA	KIT-E15-PKEA	KIT-E18-PKEA
Cooling capacity	Nominal (Min - Max)	kW	2,50 (0,85 - 3,00)	3,50 (0,85 - 4,00)	4,20 (0,98 - 5,00)	5,00 (0,98 - 6,00)
EER ¹⁾	Nominal (Min - Max)	W/W	4,85 (4,23 - 5,00)A	4,02 (3,57 - 5,00)A	3,50 (3,50 - 3,16)A	3,47 (3,50 - 3,02)A
Cooling capacity at -10°C		kW	2,63	3,69	5,04	6,00
EER at -10°C		W/W	7,19	5,96	6,01	6,00
Cooling capacity at -20°C		kW	2,61	3,66	4,06	5,82
EER at -20°C		W/W	6,71	5,56	4,39	5,39
SEER ²⁾		W/W	7,10A++	6,70A++	6,30A++	6,90A++
Pdesign		kW	2,50	3,50	4,20	5,00
Input power cooling	Nominal (Min - Max)	kW	0,52 (0,17 - 0,71)	0,87 (0,17 - 1,12)	1,20 (0,28 - 1,58)	1,44 (0,28 - 1,99)
Annual energy consumption ³⁾		kWh/a	123	183	233	254
Heating capacity	Nominal (Min - Max)	kW	3,40 (0,85 - 5,40)	4,00 (0,85 - 6,60)	5,40 (0,98 - 7,10)	5,80 (0,98 - 8,00)
Heating capacity at -7°C ⁴⁾		kW	3,33	4,07	4,10	4,98
COP ¹⁾	Nominal (Min - Max)	W/W	4,86 (4,12 - 5,15)A	4,35 (3,63 - 5,15)A	3,75 (2,88 - 3,24)A	3,82 (2,88 - 3,11)A
SCOP ⁵⁾		W/W	4,40A+	4,10A+	3,90A	4,20A+
Pdesign at -10°C		kW	2,80	3,60	3,60	4,40
Input power heating	Nominal (Min - Max)	kW	0,70 (0,17 - 1,31)	0,92 (0,17 - 1,82)	1,44 (0,34 - 2,19)	1,52 (0,34 - 2,57)
Annual energy consumption ³⁾		kWh/a	891	1229	1292	1467
Indoor unit			CS-E9PKEA	CS-E12PKEA	CS-E15PKEA	CS-E18PKEA
Power source		V	230	230	230	230
Recommended fuse		A	16	16	16	16
Connection indoor / outdoor		mm ²	4x1,5	4x1,5	4x1,5	4x2,5
Air Volume	Cool / Heat	m ³ /min	13,30 / 14,60	13,60 / 14,70	14,10 / 15,00	17,90 / 19,30
Moisture removal volume		L/h	1,50	2,00	2,40	2,80
Sound pressure ⁶⁾	Cool (Hi / Lo / Q-Lo)	dB(A)	39 / 26 / 23	42 / 29 / 26	43 / 32 / 29	44 / 37 / 34
	Heat (Hi / Lo / Q-Lo)	dB(A)	40 / 27 / 24	42 / 33 / 29	43 / 35 / 29	44 / 37 / 34
Dimension / Net weight	HxWxD	mm / kg	295x870x255 / 10	295x870x255 / 10	295x870x255 / 10	295x1070x255 / 13
Outdoor unit			CU-E9PKEA	CU-E12PKEA	CU-E15PKEA	CU-E18PKEA
Sound pressure ⁶⁾	Cool / Heat (Hi)	dB(A)	46 / 47	48 / 50	46 / 46	47 / 47
Dimension ⁷⁾	HxWxD	mm	622x824x299	622x824x299	695x875x320	695x875x320
Net weight		kg	36	36	45	46
Piping connections	Liquid pipe / Gas pipe	Inch (mm)	1/4 (6,35) / 3/8 (9,52)	1/4 (6,35) / 3/8 (9,52)	1/4 (6,35) / 1/2 (12,70)	1/4 (6,35) / 1/2 (12,70)
Pipe length range		m	3 - 15	3 - 15	3 - 15	3 - 20
Elevation difference (in/out) ⁸⁾		m	5	5	15	15
Pipe length for additional gas		m	7,5	7,5	7,5	7,5
Additional gas amount		g/m	20	20	20	20
Refrigerant (R410A)		kg/TCO ₂ Eq.	—	—	—	—
Operating range	Cool / Heat Min ~ Max	°C	-20 ~ +43 / -15 ~ +24	-20 ~ +43 / -15 ~ +24	-20 ~ +43 / -15 ~ +24	-20 ~ +43 / -15 ~ +24

Accessories

CZ-TACG1	NEW Panasonic Wifi kit for internet control
CZ-CAPRA1	RAC interface adapter for integration into P Link
PAW-WTRAY	Tray for condenser water compatible with base ground support

Accessories

PAW-GRDBSE20	Outdoor base ground support for noise and vibration absorption
PAW-GRDSTD40	Outdoor elevation platform
PAW-SERVER-PKEA	PCB for installation in server rooms with security

Rating Conditions for cooling capacity at low temperature: Cooling Indoor 27°C DB / 19°C WB, Cooling Outdoor 0°C DB / -10°C WB.

1) EER and COP calculation is based in accordance to EN14511. 2) Energy Label Scale from A+++ to D. SEER is calculated in base Eurovent IPLV for SBEM for U1 indoor unit SEER=(EER25)+b(EER50)-c(EER75)+d(EER100) where EER25, EER50, EER75 and EER100 are the EER measured value at 25%, 50%, 75% and 100% part load for temperatures 20, 25, 30 and 35°C DB, respectively. a, b, c and d are values assigned for an office type. These values are given as a=0,2, b=0,36, c=0,32 and d=0,03. The internal temperatures are taken at 27°C DB and 19°C WB. 3) The annual energy consumption is calculated in accordance to EU/626/2011. 4) Heating capacity is calculated including defrost factor correction. 5) Energy Label Scale from A+++ to D. SCOP is calculated in base Eurovent IPLV for SBEM with U1 indoor unit including defrost correction factor. 6) The sound pressure of the units shows the value measured of a position 1m in front of the main body and 1,5m from the ground. The sound pressure is measured in accordance with Eurovent 6/C/006-97 specification. 7) Add 70mm for piping port. 8) When installing the outdoor unit at a higher position than the indoor unit. // Recommended fuse for the indoor 3A.



SEER and SCOP: For KIT-E9-PKEA. SUPER QUIET: For KIT-E9-PKEA. INTERNET CONTROL: Optional.

Rating Conditions: Cooling Indoor 27°C DB / 19°C WB, Cooling Outdoor 35°C DB / 24°C WB, Heating Indoor 20°C DB, Heating Outdoor 7°C DB / 6°C WB. (DB: Dry Bulb; WB: Wet Bulb) Specifications subject to change without notice. For detailed information about ErP, please visit our websites www.aircon.panasonic.eu or www.ptc.panasonic.eu.

NEW PACi ELITE WALL MOUNTED INVERTER+ • R410A GAS



The extension of the range to include a 10kW unit allows for many more applications such as studios, gyms, high ceiling areas and even computer server rooms.

The unit's compact design and flat face ensure discreet installation, even in a small space.

High heating capacity at -7°C.

Technical focus

- 10,0kW capacity unit
- Flat face and compact design for modern appearance
- Stylish matt white color
- DC FAN for better efficiency and control
- Six directional piping outlet
- Easy connection and control of external fan or ERV using the connector PAW-FDC on the indoor unit PCB. The external device can be control by the remote control of the Panasonic indoor unit

			Single Phase					
			3,6kW	5,0kW	6,0kW	7,1kW	10,0kW	
			KIT-36PK2E5D	KIT-50PK2E5D	KIT-60PK2E5D	KIT-71PK2E5D	KIT-100PK2E5D	
Remote controller			CZ-RTC5B	CZ-RTC5B	CZ-RTC5B	CZ-RTC5B	CZ-RTC5B	
Cooling capacity	Nominal (Min - Max)	kW	3,60(1,50 - 4,00)	5,00(1,50 - 5,60)	6,10(2,00 - 7,10)	7,10(2,50 - 8,00)	9,50(3,30 - 10,50)	
EER ¹⁾	Nominal (Min - Max)	W/W	4,56(6,25 - 4,30)A	3,57(6,25 - 3,26)A	3,53(6,67 - 3,02)A	3,40(5,56 - 3,02)A	3,25(3,93 - 3,09)A	
SEER ²⁾		W/W	6,40A++	6,20A++	6,40A++	6,70A++	6,30A++	
Pdesign		kW	3,60	5,00	6,10	7,10	9,50	
Input power cooling	Nominal (Min - Max)	kW	0,79(0,24 - 0,93)	1,40(0,24 - 1,72)	1,68(0,30 - 2,35)	2,09(0,45 - 2,65)	2,92(0,84 - 3,40)	
Annual energy consumption ³⁾		kWh/a	197	282	319	371	528	
Heating capacity	Nominal (Min - Max)	kW	4,00(1,50 - 5,00)	5,60(1,50 - 6,50)	7,00(1,80 - 8,00)	8,00(2,00 - 9,00)	9,50(4,10 - 11,50)	
Heating capacity at -7°C / -15°C ⁴⁾		kW	-/-	-/-	-/-	-/-	-/-	
COP ¹⁾	Nominal (Min - Max)	W/W	4,71(7,89 - 4,20)A	3,94(7,89 - 3,39)A	4,22(9,00 - 3,90)A	4,00(5,00 - 3,10)A	3,97(4,56 - 3,43)A	
SCOP ²⁾		W/W	4,30A+	4,10A+	4,20A+	4,10A+	3,80A	
Pdesign at -10°C		kW	3,60	5,00	6,00	7,10	9,50	
Input power heating	Nominal (Min - Max)	kW	0,85(0,19 - 1,19)	1,42(0,19 - 1,92)	1,66(0,20 - 2,05)	2,00(0,40 - 2,90)	2,92(0,84 - 3,40)	
Annual energy consumption ³⁾		kWh/a	1172	1707	2000	2424	3325	
Indoor unit			S-36PK2E5B	S-50PK2E5B	S-60PK2E5B	S-71PK2E5B	S-100PK2E5B	
Air volume	Hi / Med / Lo	m ³ /min	13,00/11,00/9,00	16,00/17,50/11,00	20,00/17,50/14,50	20,00/17,50/14,50	22,00/18,50/15,00	
Sound pressure ⁵⁾	Hi / Med / Lo	dB(A)	35/31/27	40/36/32	47/44/40	47/44/40	49/45/41	
Dimension	HxWxD	mm	302x1120x236	302x1120x236	302x1120x236	302x1120x236	302x1120x236	
Net weight		kg	13	13	14	14	14	
Outdoor unit			U-36PE2E5A	U-50PE2E5A	U-60PE2E5A	U-71PE1E5A	U-100PE1E5A	
Power source		V	220/230/240	220/230/240	220/230/240	220/230/240	220/230/240	
Recommended fuse		A	—	—	—	—	—	
Connection indoor / outdoor		mm ²	—	—	—	—	—	
Current	Cool	A	3,85/3,70/3,55	6,60/6,30/6,05	8,45/8,05/9,75	9,70/9,40/9,10	13,40/12,90/12,40	
	Heat	A	4,15/3,95/3,80	6,75/6,45/6,20	8,10/7,75/7,40	9,20/8,40/8,60	10,90/10,50/10,20	
Air volume	Cool / Heat	m ³ /min	38/38	38/41	38/41	60/60	110/95	
Sound pressure	Cool / Heat (Hi)	dB(A)	45/46	46/48	46/49	48/50	52/52	
Dimension	HxWxD	mm	619x799x299	619x799x299	619x799x299	996x940x340	1416x940x340	
Net weight		kg	39	39	40	69	98	
Piping connections	Liquid pipe	Inch (mm)	1/4(6,35)	1/4(6,35)	3/8(9,52)	3/8(9,52)	3/8(9,52)	
	Gas pipe	Inch (mm)	1/2(12,70)	1/2(12,70)	5/8(15,88)	5/8(15,88)	5/8(15,88)	
Pipe length range		m	3 - 40	3 - 40	3 - 40	5 - 50	5 - 75	
Elevation difference (in/out) ⁶⁾		m	30	30	30	30	30	
Pipe length for additional gas		m	30	30	30	30	30	
Additional gas amount		g/m	20	20	40	50	50	
Refrigerant (R410A)		kg/TCO ₂ Eq.	1,40/2,9232	1,40/2,9232	1,95/4,0716	2,35/4,9068	3,40/7,0992	
Operating range	Cool Min ~ Max	°C	-15 ~ +46	-15 ~ +46	-15 ~ +46	-15 ~ +46	-15 ~ +46	
	Heat Min ~ Max	°C	-20 ~ +24	-20 ~ +24	-20 ~ +24	-20 ~ +24	-20 ~ +24	

Accessories	
CZ-RTC5B	Wired remote controller with Econavi button and datanavi
CZ-RWSK2	Wireless remote controller
CZ-RE2C2	Simplified remote controller
PAW-GRDSTD40	Outdoor elevation platform 400x900x400mm
PAW-WTRAY	Tray for condenser water compatible with base ground support
PAW-GRDBSE20	Outdoor base ground support for noise and vibration absorption

Accessories	
PAW-WPH7	Wind protection shield for 5kW outdoor unit
PAW-WPH9	Wind protection shield for outdoor units 6/7kW Elite and 10/12,5kW Standard
PAW-WPH10	Wind protection shield for outdoor units from 10 to 14kW Elite and 14kW Standard
PAW-PACR3	Interfaces to run 3 units on Backup and alternative run

PACi Kits

R410A



Optional Controller. Wired remote controller CZ-RTCSB
 Compatible with Econavi
 Optional Controller. Wireless remote controller CZ-RWSK2
 Optional Controller. Simplified remote controller CZ-REZC2
 Optional Econavi Sensor. CZ-CENSC1



Closed discharge port.

When the unit is turned OFF, the flap closes completely to prevent dust getting into the unit and to keep the equipment clean.

Quiet operation.

These units are among the quietest in the industry, making them ideal for hotels and hospitals.

Smooth and durable design.

The sleek, compact design ensures a discreet installation - even where space is limited.

Piping outlet in six directions.

Piping outlet is possible in the six directions of right, right rear, right bottom, left, left rear and left bottom, making the installation work easier.

Air distribution is altered depending on the operational mode of the unit.

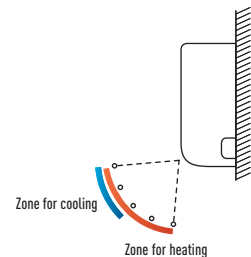

			Three Phase	
			7,1kW	10,0kW
KIT			KIT-71PK2E8D	KIT-100PK2E8D
Remote controller			CZ-RTC5B	CZ-RTC5B
Cooling capacity	Nominal (Min - Max)	kW	7,10 (3,20 - 8,00)	9,50 (3,30 - 10,50)
EER ¹⁾	Nominal (Min - Max)	W/W	3,40 (5,71 - 3,02) A	3,25 (3,93 - 3,09) A
SEER ²⁾		W/W	6,50 A++	6,10 A+
Pdesign		kW	7,10	9,50
Input power cooling	Nominal (Min - Max)	kW	2,09 (0,56 - 2,65)	2,92 (0,84 - 3,40)
Annual energy consumption ³⁾		kWh/a	382	545
Heating capacity	Nominal (Min - Max)	kW	8,00 (2,80 - 9,00)	9,50 (4,10 - 11,50)
Heating capacity at -7°C / -15°C ⁴⁾		kW	- / -	- / -
COP ¹⁾	Nominal (Min - Max)	W/W	4,00 (5,60 - 3,10) A	3,97 (4,56 - 3,43) A
SCOP ²⁾		W/W	4,10 A+	4,00 A+
Pdesign at -10°C		kW	7,10	9,50
Input power heating	Nominal (Min - Max)	kW	2,00 (0,50 - 2,90)	2,39 (0,90 - 3,35)
Annual energy consumption ³⁾		kWh/a	2424	3325
Indoor unit			S-71PK2E5B	S-100PK2E5B
Air volume	Hi / Med / Lo	m ³ /min	20,00 / 17,50 / 14,50	22,00 / 18,50 / 15,00
Sound pressure ⁵⁾	Hi / Med / Lo	dB(A)	47 / 44 / 40	49 / 45 / 41
Dimension	H x W x D	mm	302 x 1120 x 236	302 x 1120 x 236
Net weight		kg	14	14
Outdoor unit			U-71PE1E8A	U-100PE1E8A
Power source		V	380 / 400 / 415	380 / 400 / 415
Recommended fuse		A	16	16
Connection indoor / outdoor		mm ²	2,50	2,50
Current	Cool	A	3,25 / 3,10 / 3,00	4,60 / 4,35 / 4,30
	Heat	A	3,05 / 3,00 / 2,85	3,70 / 3,55 / 3,45
Air volume	Cool / Heat	m ³ /min	60 / 60	110 / 95
Sound pressure	Cool / Heat (Hi)	dB(A)	48 / 50	52 / 52
Dimension	H x W x D	mm	996 x 940 x 340	1416 x 940 x 340
Net weight		kg	71	98
Piping connections	Liquid pipe	Inch (mm)	3/8 (9,52)	3/8 (9,52)
	Gas pipe	Inch (mm)	5/8 (15,88)	5/8 (15,88)
Pipe length range		m	5 - 50	5 - 75
Elevation difference (in/out) ⁶⁾		m	30	30
Pipe length for additional gas		m	30	30
Additional gas amount		g/m	50	50
Refrigerant (R410A)		kg / TCO ₂ Eq.	2,35 / 4,9068	3,40 / 7,0992
Operating range	Cool Min ~ Max	°C	-15 ~ +46	-15 ~ +46
	Heat Min ~ Max	°C	-20 ~ +24	-20 ~ +24

1) EER and COP calculation is based in accordance to EN14511. 2) For models below 12kW, the SCOP is calculated based on values of EU/626/2011. For models above 12kW, the SCOP is calculated based on values of EU/2281/2016. 3) The annual energy consumption is calculated in accordance to EU/626/2011. 4) Heating capacity is calculated including defrost factor correction. 5) The sound pressure of the units shows the value measured at a position 1m in front of the main body and 1,5m from the ground. The sound pressure is measured in accordance with Eurovent 6/C/006-97 specification. 6) When installing the outdoor unit at a higher position than the indoor unit.* Recommended fuse for the indoor 3A.



SEER: For KIT-71PK2E5D. SCOP: For KIT-36PK2E5D. INTERNET CONTROL: Optional.
 Compatible with all Panasonic connectivity solutions. For detailed information go to the Control Systems section.

Rating Conditions: Cooling Indoor 27°C DB / 19°C WB. Cooling Outdoor 35°C DB / 24°C WB. Heating Indoor 20°C DB. Heating Outdoor 7°C DB / 6°C WB. (DB: Dry Bulb; WB: Wet Bulb)
 Specifications subject to change without notice. For detailed information about ErP, please visit our websites www.aircon.panasonic.eu or www.gtc.panasonic.eu.

NEW PACi STANDARD WALL MOUNTED INVERTER+ • R410A GAS

NEW
18



The extension of the range to include a 10kW unit allows for many more applications such as studios, gyms, high ceiling areas and even computer server rooms.

The unit's compact design and flat face ensure discreet installation, even in a small space.

High heating capacity at -7°C.

Technical focus

- 10,0kW capacity unit
- Flat face and compact design for modern appearance
- Stylish matt white color
- DC FAN for better efficiency and control
- Six directional piping outlet
- Easy connection and control of external fan or ERV using the connector PAW-FDC on the indoor unit PCB. The external device can be control by the remote control of the Panasonic indoor unit

			Single Phase		
			6,1kW	7,1kW	10,0kW
KIT			KIT-60PKY2E5D	KIT-71PKY2E5D	KIT-100PKY2E5D
Remote controller			CZ-RTC5B	CZ-RTC5B	CZ-RTC5B
Cooling capacity	Nominal (Min - Max)	kW	6,10(2,00 - 7,10)	7,10(2,00 - 7,70)	9,00(2,70 - 9,70)
EER ¹⁾	Nominal (Min - Max)	W/W	3,47(6,67 - 3,02)A	2,90(6,67 - 2,61)C	2,67(5,09 - 2,55)D
SEER ²⁾		W/W	5,70A+	5,40A	5,90A+
Pdesign		kW	6,10	7,10	9,00
Input power cooling	Nominal (Min - Max)	kW	1,76(0,30 - 2,35)	2,45(0,30 - 2,95)	3,37(0,53 - 3,80)
Annual energy consumption ³⁾		kWh/a	375	460	534
Heating capacity	Nominal (Min - Max)	kW	6,10(1,80 - 7,00)	7,10(1,80 - 8,10)	9,00(2,10 - 10,50)
Heating capacity at -7°C / -15°C ⁴⁾		kW	- / -	- / -	9,97/8,43
COP ¹⁾	Nominal (Min - Max)	W/W	4,30(9,00 - 4,12)A	4,20(9,00 - 3,60)A	3,78(5,12 - 3,50)A
SCOP ²⁾		W/W	4,00A+	4,00A+	3,90A
Pdesign at -10°C		kW	6,00	6,00	9,00
Input power heating	Nominal (Min - Max)	kW	1,42(0,20 - 1,70)	1,69(0,20 - 2,25)	2,38(0,41 - 3,00)
Annual energy consumption ³⁾		kWh/a	2100	2100	3231
Indoor unit			S-60PK2E5B	S-71PK2E5B	S-100PK2E5B
Air volume	Hi / Med / Lo	m ³ /min	20,00/17,50/14,50	20,00/17,50/14,50	22,00/18,50/15,00
Sound pressure ⁵⁾	Hi / Med / Lo	dB(A)	47/44/40	47/44/40	49/45/41
Dimension	HxWxD	mm	302x1120x236	302x1120x236	302x1120x236
Net weight		kg	14	14	14
Outdoor unit			U-60PEY2E5	U-71PEY2E5	U-100PEY1E5
Power source		V	220/230/240	220/230/240	220/230/240
Recommended fuse		A	-	-	25
Connection indoor / outdoor		mm ²	-	-	4,0
Current	Cool	A	8,60/8,20/7,85	12,00/11,40/11,00	16,00/15,30/14,60
	Heat	A	6,85/6,55/6,30	8,25/7,85/7,55	10,90/10,60/10,10
Air volume	Cool / Heat	m ³ /min	38/41	44/41	76/67
Sound pressure	Cool / Heat (Hi)	dB(A)	46/48	49/49	54/54
Dimension	HxWxD	mm	619x799x299	619x799x299	996x940x340
Net weight		kg	40	40	73
Piping connections	Liquid pipe	Inch (mm)	3/8(9,52)	3/8(9,52)	3/8(9,52)
	Gas pipe	Inch (mm)	5/8(15,88)	5/8(15,88)	5/8(15,88)
Pipe length range		m	3 - 40	3 - 40	5 - 50
Elevation difference (in/out) ⁶⁾		m	30	30	30
Pipe length for additional gas		m	30	30	30
Additional gas amount		g/m	40	40	50
Refrigerant (R410A)		kg/TCO ₂ Eq.	1,95/4,0716	1,95/4,0716	2,60/5,4288
Operating range	Cool Min - Max	°C	-10 - +43	-10 - +43	-10 / +43
	Heat Min - Max	°C	-15 - +24	-15 - +24	-15 / +24

Accessories

CZ-RTC5B	Wired remote controller with Econavi button and datanavi
CZ-RWSK2	Wireless remote controller
CZ-RE2C2	Simplified remote controller
PAW-GRDSTD40	Outdoor elevation platform 400x900x400mm
PAW-WTRAY	Tray for condenser water compatible with base ground support
PAW-GRDBSE20	Outdoor base ground support for noise and vibration absorption

Accessories

PAW-WPH7	Wind protection shield for 5kW outdoor unit
PAW-WPH9	Wind protection shield for outdoor units 6/7kW Elite and 10/12,5kW Standard
PAW-WPH10	Wind protection shield for outdoor units from 10 to 14kW Elite and 14kW Standard
PAW-PACR3	Interfaces to run 3 units on Backup and alternative run

PACi Kits

R410A



Optional Controller.
Wired remote controller
CZ-RTCSB
Compatible with Econavi



Optional Controller
Wireless remote controller
CZ-RWSK2



Optional Controller.
Simplified remote controller
CZ-REZC2



Optional Econavi Sensor.
CZ-CENSC1



Closed discharge port.

When the unit is turned OFF, the flap closes completely to prevent dust getting into the unit and to keep the equipment clean.

Quiet operation.

These units are among the quietest in the industry, making them ideal for hotels and hospitals.

Smooth and durable design.

The sleek, compact design ensures a discreet installation - even where space is limited.

Piping outlet in six directions.

Piping outlet is possible in the six directions of right, right rear, right bottom, left, left rear and left bottom, making the installation work easier.

Air distribution is altered depending on the operational mode of the unit.

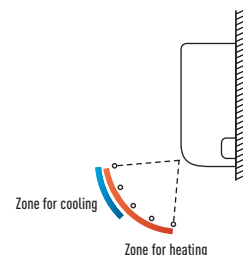

			Three Phase
			10,0kW
			KIT-100PKY2E8D
			CZ-RTCSB
KIT			
Remote controller			
Cooling capacity	Nominal (Min - Max)	kW	9,00 (2,70 - 9,70)
EER ¹⁾	Nominal (Min - Max)	W/W	2,67 (5,09 - 2,55) D
SEER ²⁾		W/W	5,80 A+
Pdesign		kW	9,00
Input power cooling	Nominal (Min - Max)	kW	3,37 (0,53 - 3,80)
Annual energy consumption ³⁾		kWh/a	543
Heating capacity	Nominal (Min - Max)	kW	9,00 (2,10 - 10,50)
Heating capacity at -7°C / -15°C ⁴⁾		kW	9,97 / 8,43
COP ¹⁾	Nominal (Min - Max)	W/W	3,78 (5,12 - 3,50) A
SCOP ²⁾		W/W	3,90 A
Pdesign at -10°C		kW	9,00
Input power heating	Nominal (Min - Max)	kW	2,38 (0,41 - 3,00)
Annual energy consumption ³⁾		kWh/a	3231
Indoor unit			S-100PK2E5B
Air volume	Hi / Med / Lo	m ³ /min	22,00 / 18,50 / 15,00
Sound pressure ⁵⁾	Hi / Med / Lo	dB(A)	49 / 45 / 41
Dimension	H x W x D	mm	302 x 1120 x 236
Net weight		kg	14
Outdoor unit			U-100PEY1E8
Power source		V	380 / 400 / 415
Recommended fuse		A	16
Connection indoor / outdoor		mm ²	2,5
Current	Cool	A	5,40 / 5,10 / 4,95
	Heat	A	3,75 / 3,55 / 3,45
Air volume	Cool / Heat	m ³ /min	76 / 67
Sound pressure	Cool / Heat (Hi)	dB(A)	54 / 54
Dimension	H x W x D	mm	996 x 940 x 340
Net weight		kg	73
Piping connections	Liquid pipe	Inch (mm)	3/8 (9,52)
	Gas pipe	Inch (mm)	5/8 (15,88)
Pipe length range		m	5 - 50
Elevation difference (in/out) ⁶⁾		m	30
Pipe length for additional gas		m	30
Additional gas amount		g/m	50
Refrigerant (R410A)		kg / TCO ₂ Eq.	2,60 / 5,4288
Operating range	Cool Min ~ Max	°C	-10 / +43
	Heat Min ~ Max	°C	-15 / +24

1) EER and COP calculation is based in accordance to EN14511. 2) For models below 12kW, the SCOP is calculated based on values of EU/626/2011. For models above 12kW, the SCOP is calculated based on values of EU/2281/2016. 3) The annual energy consumption is calculated in accordance to EU/626/2011. 4) Heating capacity is calculated including defrost factor correction. 5) The sound pressure of the units shows the value measured of a position 1m in front of the main body and 1,5m from the ground. The sound pressure is measured in accordance with Eurovent 6/C/006-97 specification. 6) When installing the outdoor unit at a higher position than the indoor unit.* Recommended fuse for the indoor 3A.



SEER and SCOP: For KIT-100PKY2E5D. INTERNET CONTROL: Optional.
Compatible with all Panasonic connectivity solutions. For detailed information go to the Control Systems section.

Rating Conditions: Cooling Indoor 27°C DB / 19°C WB. Cooling Outdoor 35°C DB / 24°C WB. Heating Indoor 20°C DB. Heating Outdoor 7°C DB / 6°C WB. (DB: Dry Bulb; WB: Wet Bulb)
Specifications subject to change without notice. For detailed information about ErP, please visit our websites www.aircon.panasonic.eu or www.gtc.panasonic.eu.

PACi ELITE 4 WAY 60x60 CASSETTE INVERTER+ • R410A GAS



Small and powerful, ideal for offices and restaurants. Standard units only for Twin, Triple and Double-twin combinations.

High heating capacity at -7°C.

Technical focus

- Fresh air knock out
- Multidirectional air flow
- Integrated drain pump gives 850mm lift
- 3 speed centrifugal fan
- DC FAN for better efficiency and control
- Easy connection and control of external fan or ERV using the connector PAW-FDC on the indoor unit PCB. The external device can be control by the remote control of the Panasonic indoor unit

			Single Phase	
			3,6kW	5,0kW
KIT			KIT-36PY2E5C	KIT-50PY2E5C
Remote controller			CZ-RTCSB	CZ-RTCSB
Cooling capacity	Nominal (Min - Max)	kW	3,60(1,50 - 4,00)	5,00(1,50 - 5,60)
EER ¹⁾	Nominal (Min - Max)	W/W	4,50(6,25 - 421)A	3,47(6,25 - 3,16)A
SEER ²⁾		W/W	6,30A++	6,10A++
Pdesign		kW	3,60	5,00
Input power cooling	Nominal (Min - Max)	kW	0,80(0,24 - 0,95)	1,44(0,24 - 1,77)
Annual energy consumption ³⁾		kWh/a	200	287
Heating capacity	Nominal (Min - Max)	kW	4,00(1,50 - 5,00)	5,60(1,50 - 6,50)
COP ¹⁾	Nominal (Min - Max)	W/W	4,08(7,89 - 3,68)A	3,31(7,89 - 3,00)C
SCOP ²⁾		W/W	4,10A+	3,90A
Pdesign at -10°C		kW	3,60	5,00
Input power heating	Nominal (Min - Max)	kW	0,98(0,19 - 1,36)	1,69(0,19 - 2,17)
Annual energy consumption ³⁾		kWh/a	1229	1795
Indoor unit			S-36PY2E5A	S-50PY2E5A
Air volume	Cool — Heat (Hi / Med / Lo)	m ³ /min	9,70/8,00/6,00 — 9,90/8,20/6,00	11,10/9,80/8,50 — 11,10/9,80/8,70
Moisture removal volume		L/h	2,1	2,8
Sound pressure ⁴⁾	Hi / Me / Lo	dB(A)	36/32/26	40/37/33
Sound power	Hi / Me / Lo	dB	51/47/41	55/52/48
Dimension (H x W x D) / Net weight	Indoor	mm / kg	288 x 583 x 583 / 18	288 x 583 x 583 / 18
	CZ-KPY3AW Panel	mm / kg	31 x 700 x 700 / 2,4	31 x 700 x 700 / 2,4
	CZ-KPY3BW Panel	mm / kg	31 x 625 x 625 / 2,4	31 x 625 x 625 / 2,4
Outdoor unit			U-36PE2E5A	U-50PE2E5A
Power source		V	220/230/240	220/230/240
Current	Cool / Heat	A	3,80/3,60/3,50 — 4,70/4,50/4,35	6,70/6,50/6,20 — 8,05/7,70/7,40
Air volume	Cool / Heat	m ³ /min	38/38	38/41
Sound pressure	Cool / Heat (Hi)	dB(A)	45/46	46/48
Sound power	Cool / Heat (Hi)	dB	64/66	65/68
Dimension / Net weight	H x W x D	mm / kg	619 x 799 x 299 / 39	619 x 799 x 299 / 39
Piping connections	Liquid pipe / Gas pipe	Inch (mm)	1/4(6,35) / 1/2(12,70)	1/4(6,35) / 1/2(12,70)
Pipe length range / Elevation difference (in/out) ⁵⁾		m	3 - 40/30	3 - 40/30
Pipe length for additional gas / Additional gas amount		m / g/m	30/20	30/20
Refrigerant (R410A)		kg/TCO ₂ Eq.	1,40/2,9232	1,40/2,9232
Operating range	Cool / Heat Min ~ Max	°C	-15 - +46 / -20 - +24	-15 - +46 / -20 - +24

Accessories	
CZ-RTCSB	Wired remote controller with Econavi button and datanavi
CZ-RWSK2	Wireless remote controller
CZ-RE2C2	Simplified remote controller
PAW-WTRAY	Tray for condenser water compatible with base ground support

Accessories	
PAW-GRDBSE20	Outdoor base ground support for noise and vibration absorption
PAW-GRDSTD40	Outdoor elevation platform 400 x 900 x 400mm
PAW-WPH7	Wind protection shield for 5kW outdoor unit

1) EER and COP calculation is based in accordance to EN14511. 2) For models below 12kW, the SCOP is calculated based on values of EU/626/2011. For models above 12kW, the SCOP is calculated based on values of EU/2281/2016. 3) The annual energy consumption is calculated in accordance to EU/626/2011. 4) The sound pressure of the units shows the value measured of a position 1m in front of the main body and 1,5m from the ground. The sound pressure is measured in accordance with Eurovent 6/C/006-97 specification. 5) When installing the outdoor unit at a higher position than the indoor unit.* Recommended fuse for the indoor 3A.



SEER and SCOP: For KIT-36PY2E5C. INTERNET CONTROL: Optional.
Compatible with all Panasonic connectivity solutions. For detailed information go to the Control Systems section.

PACi STANDARD 4 WAY 60X60 CASSETTE INVERTER+ • R410A GAS



Optional Controller.
Wired remote controller
CZ-RIC5B
Compatible with Econavi



Optional Controller
Wireless remote controller
CZ-RWSK2



Optional Controller.
Simplified remote controller
CZ-RE2CZ

A drain height of approximately 850mm from the ceiling surface

The drain height can be increased by approx. 350mm over the conventional value by using a high-lift drain pump, and long horizontal piping is possible.

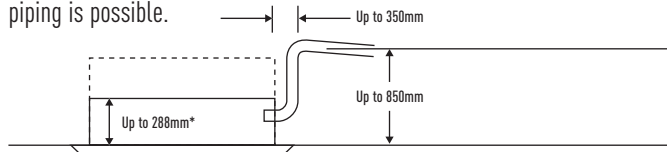

A lightweight unit at 18kg the unit is also very slim with a height of only 288mm, making installation possible even in narrow ceilings.

Lighter and slimmer, easier installation

Lightweight and very slim which makes installation possible even in narrow ceilings.

Designed to fit exactly into a 600x600mm ceiling grid without the need to alter the bar configuration.

Significant reduction of power consumption by using highly developed DC fan motors with variable speed, special heat exchangers, etc.

			3,6kW	4,5kW	5,0kW
Indoor unit			S-36PY2E5A ¹⁾	S-45PY2E5A ¹⁾	S-50PY2E5A
Cooling capacity		kW	3,60	4,50	5,00
Heating capacity		kW	4,20	5,20	5,60
Current	Cooling	A	0,30	0,32	0,35
	Heating	A	0,30	0,30	0,35
Input power	Cooling	kW	0,40	0,40	0,45
	Heating	kW	0,35	0,35	0,40
Air volume	Cool / Heat	m ³ /min	10,00/10,00	10,00/10,00	11,00/11,00
Moisture removal volume		L/h	2,1	2,5	2,8
Sound pressure ⁴⁾	Cool (Hi / Med / Lo)	dB(A)	36/32/26	38/34/28	40/37/33
	Heat (Hi / Med / Lo)	dB(A)	36/32/26	38/34/28	40/37/33
Sound power	Cool (Hi)	dB	51/47/41	53/49/43	55/52/48
	Heat (Hi)	dB	51/47/41	53/49/43	55/52/48
Dimension (HxWxD)	Indoor	mm	288 x 583 x 583	288 x 583 x 583	288 x 583 x 583
	Panel CZ-KPY3AW	mm	31 x 700 x 700	31 x 700 x 700	31 x 700 x 700
	Panel CZ-KPY3BW	mm	31 x 625 x 625	31 x 625 x 625	31 x 625 x 625
Net weight	Indoor	kg	18	18	18
	Panel	kg	2,4	2,4	2,4
Piping connections	Liquid pipe	Inch (mm)	1/4 [6,35]	1/4 [6,35]	1/4 [6,35]
	Gas pipe	Inch (mm)	1/2 [12,70]	1/2 [12,70]	1/2 [12,70]
Operating range	Cool Min ~ Max	°C	+18 ~ +32	+18 ~ +32	+18 ~ +32
	Heat Min ~ Max	°C	+16 ~ +30	+16 ~ +30	+16 ~ +30

1) Only for multi combinations.
Recommended fuse for the indoor 3A.

PACi ELITE 4 WAY 90x90 CASSETTE INVERTER+ • R410A GAS



Panel:
CZ-KPU3 (standard panel)
CZ-KPU3A (Econavi exclusive panel)

Large capacity PACi. Trusted power and high efficiency.

Thanks to advances in design and technology such as the high performance turbo fan, more efficient and silent, the nanoe™ X air cleaner, the U2 Panasonic 4 way 90x90 cassette offers high energy saving, fresh air and comfort.

Technical focus

- High performance turbo fan, path system for heat exchanger
- Lower noise in slow fan operation
- Light weight, easy piping
- Easy installation structure of the panel
- Econavi: Floor temperature and humidity sensor added. Activity amount detection and new circulator
- nanoe™ X: The first air purifier technology in commercial air conditioning

			Single Phase						
			3,6kW	5,0kW	6,0kW	7,1kW	10,0kW	12,5kW	14,0kW
KIT			KIT-36PU2E5D	KIT-50PU2E5D	KIT-60PU2E5D	KIT-71PU2E5D	KIT-100PU2E5D	KIT-125PU2E5D	KIT-140PU2E5D
Remote controller			CZ-RTC5B	CZ-RTC5B	CZ-RTC5B	CZ-RTC5B	CZ-RTC5B	CZ-RTC5B	CZ-RTC5B
Cooling capacity	Nominal (Min - Max)	kW	3,60(1,50 - 4,00)	5,00(1,50 - 5,60)	6,00(2,00 - 7,10)	7,10(2,50 - 8,00)	10,00(3,03 - 12,50)	12,50(3,30 - 14,00)	14,00(3,30 - 15,50)
EER ¹⁾	Nominal (Min - Max)	W/W	4,68(6,25 - 4,40)A	3,79(6,25 - 3,46)A	3,75(8,00 - 3,23)A	3,94(5,56 - 3,02)A	4,27(4,29 - 3,38)A	3,70(4,29 - 3,04)A	3,30(4,29 - 2,70)A
SEER ²⁾		W/W	7,40A++	7,10A++	7,40A++	7,60A++	7,60A++	6,91	6,52
Pdesign		kW	3,60	5,00	6,00	7,10	10,00	12,50	14,00
Input power cooling	Nominal (Min - Max)	kW	0,77(0,24 - 0,91)	1,32(0,24 - 1,62)	1,60(0,25 - 2,20)	1,80(0,45 - 2,65)	2,34(0,77 - 3,70)	3,37(0,77 - 4,60)	4,24(0,77 - 5,74)
Annual energy consumption ³⁾		kWh/a	170	246	284	327	461	—	—
Heating capacity	Nominal (Min - Max)	kW	4,00(1,50 - 5,00)	5,60(1,50 - 6,50)	7,00(1,80 - 8,00)	8,00(2,00 - 9,00)	11,20(4,10 - 14,00)	14,00(4,10 - 16,00)	16,00(4,10 - 18,00)
Heating capacity at -7°C / -15°C ⁴⁾		kW	— / —	— / —	— / —	— / —	— / —	— / —	— / —
COP ¹⁾	Nominal (Min - Max)	W/W	5,13(7,89 - 4,63)A	4,44(7,89 - 4,01)A	4,07(9,00 - 3,90)A	4,30(5,00 - 3,16)A	5,00(5,19 - 3,18)A	4,60(5,19 - 3,17)A	4,30(5,19 - 3,15)A
SCOP ²⁾		W/W	4,60A++	4,40A+	4,20A+	4,30A+	4,80A++	4,10	3,90
Pdesign at -10°C		kW	3,60	5,00	6,00	7,10	10,00	12,50	14,00
Input power heating	Nominal (Min - Max)	kW	0,78(0,19 - 1,08)	1,26(0,19 - 1,62)	1,72(0,20 - 2,05)	1,86(0,40 - 2,85)	2,24(0,79 - 4,40)	3,04(0,79 - 5,04)	3,72(0,79 - 5,72)
Annual energy consumption ³⁾		kWh/a	1095	1591	1999	2312	2917	—	—
Indoor unit			S-36PU2E5B	S-50PU2E5B	S-60PU2E5B	S-71PU2E5B	S-100PU2E5B	S-125PU2E5B	S-140PU2E5B
Air volume	Hi / Med / Lo	m ³ /min	14,50/13,00/11,50	16,50/13,50/11,50	21,00/16,00/13,00	22,00/16,00/13,00	36,00/26,00/18,00	37,00/27,00/19,00	38,00/29,00/20,00
Sound pressure ⁵⁾	Hi / Med / Lo	dB(A)	30/28/27	32/29/27	36/31/28	37/31/28	45/38/32	46/39/33	47/40/34
Dimension	Indoor (HxWxD)	mm	256x840x840	256x840x840	256x840x840	256x840x840	319x840x840	319x840x840	319x840x840
	Panel (HxWxD)	mm	33,5x950x950	33,5x950x950	33,5x950x950	33,5x950x950	33,5x950x950	33,5x950x950	33,5x950x950
Net weight	Indoor / Panel	kg	19 / 5	19 / 5	20 / 5	20 / 5	25 / 5	25 / 5	25 / 5
Outdoor unit			U-36PE2E5A	U-50PE2E5A	U-60PE2E5A	U-71PE1E5A	U-100PE1E5A	U-125PE1E5A	U-140PE1E5A
Power source		V	220/230/240	220/230/240	220/230/240	220/230/240	220/230/240	220/230/240	220/230/240
Recommended fuse		A	—	—	—	20	25	30	16
Connection indoor / outdoor		mm ²	—	—	—	2,5	4,0	6,0	2,5
Current	Cool	A	3,75/3,55/3,40	6,25/5,95/5,70	7,90/7,50/7,25	8,40/8,10/7,90	10,50/10,10/9,70	15,20/14,70/14,30	19,30/18,60/18,00
	Heat	A	3,80/3,60/3,45	6,05/5,75/5,50	8,50/8,15/7,80	8,60/8,25/8,00	10,10/9,70/9,40	13,70/13,30/12,90	16,90/16,30/15,80
Air volume	Cool / Heat	m ³ /min	38/38	38/41	38/41	60/60	110/95	130/110	135/120
Sound pressure	Cool / Heat (Hi)	dB(A)	45/46	46/48	46/49	48/50	52/52	53/53	54/55
Dimension	HxWxD	mm	619x799x299	619x799x299	619x799x299	996x940x340	1416x940x340	1416x940x340	1416x940x340
Net weight		kg	39	39	40	69	98	98	98
Piping connections	Liquid pipe	Inch (mm)	1/4(6,35)	1/4(6,35)	3/8(9,52)	3/8(9,52)	3/8(9,52)	3/8(9,52)	3/8(9,52)
	Gas pipe	Inch (mm)	1/2(12,70)	1/2(12,70)	5/8(15,88)	5/8(15,88)	5/8(15,88)	5/8(15,88)	5/8(15,88)
Pipe length range		m	3 - 40	3 - 40	3 - 40	5 - 50	5 - 75	5 - 75	5 - 75
Elevation difference [in/out] ⁶⁾		m	30	30	30	30	30	30	30
Pipe length for additional gas		m	30	30	30	30	30	30	30
Additional gas amount		g/m	20	20	40	50	50	50	50
Refrigerant (R410A)		kg/TCO ₂ Eq.	1,40/2,9232	1,40/2,9232	1,95/4,0716	2,35/4,9068	3,40/7,0992	3,40/7,0992	3,40/7,0992
Operating range	Cool Min ~ Max	°C	-15 ~ +46	-15 ~ +46	-15 ~ +46	-15 ~ +46	-15 ~ +46	-15 ~ +46	-15 ~ +46
	Heat Min ~ Max	°C	-20 ~ +24	-20 ~ +24	-20 ~ +24	-20 ~ +24	-20 ~ +24	-20 ~ +24	-20 ~ +24

Accessories	
CZ-RTC5B	Wired remote controller with Econavi button and datanavi
CZ-RWSU3	Wireless remote controller
CZ-RE2C2	Simplified remote controller
CZ-CNEXU1	nanoe™ X air purifying system
CZ-KPU3A	Econavi exclusive panel
PAW-WTRAY	Tray for condenser water compatible with base ground support

Accessories	
PAW-GRDBSE20	Outdoor base ground support for noise and vibration absorption
PAW-WPH7	Wind protection shield for 5kW outdoor unit
PAW-WPH9	Wind protection shield for outdoor units 6/7kW Elite and 10/12,5kW Standard
PAW-WPH10	Wind protection shield for outdoor units from 10 to 14kW Elite and 14kW Standard

PACi Kits

R410A



Optional Controller. Wired remote controller CZ-RTCSB Compatible with Econavi and nanoe™ X
 Optional Controller. Wireless remote controller CZ-RWSU3
 Optional Controller. Simplified remote controller CZ-REZC2
 Econavi panel: CZ-KPU3A (CZ-RTCSB is required)
 Optional nanoe™ X kit: CZ-CNEXU1 (CZ-RTCSB is required)



Group control, new circulation function

Do circulating operation when nobody there, and mix air in the whole room. Minimize temperature gap in both heating and cooling operation.

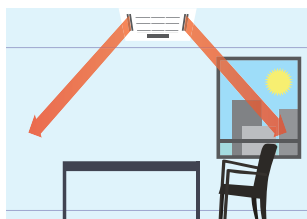

Circulation by Detecting no movement (10min.)



Indirect air flow by detecting movement

2 types of body with height difference (same as current ones)

25,6cm and 31,9cm.

Always fresh and clean air with nanoe™ X

nanoe™ X is newly developed for PACi cassette by the advanced technology of Room Air conditioning.



CZ-RTCSB and optional accessory CZ-CNEXU1 are required to use nanoe™ X function.

Three Phase

KIT			7,1kW	10,0kW	12,5kW	14,0kW
			KIT-71PU2E8D CZ-RTCSB	KIT-100PU2E8D CZ-RTCSB	KIT-125PU2E8D CZ-RTCSB	KIT-140PU2E8D CZ-RTCSB
Remote controller						
Cooling capacity	Nominal (Min - Max)	kW	7,10 (3,20 - 8,00)	10,00 (3,30 - 12,50)	12,50 (3,30 - 14,00)	14,00 (3,30 - 15,00)
EER ¹⁾	Nominal (Min - Max)	W/W	3,94 (5,71 - 3,02) A	4,27 (4,29 - 3,38) A	3,70 (4,29 - 3,04) A	3,30 (4,29 - 2,70) A
SEER ²⁾		W/W	7,30 A++	7,40 A++	6,89	6,50
Pdesign		kW	7,10	10,00	12,50	14,00
Input power cooling	Nominal (Min - Max)	kW	1,80 (0,56 - 2,65)	2,34 (0,77 - 3,70)	3,37 (0,77 - 4,60)	4,24 (0,77 - 5,74)
Annual energy consumption ³⁾		kWh/a	340	473	—	—
Heating capacity	Nominal (Min - Max)	kW	8,00 (2,80 - 9,00)	11,20 (4,10 - 14,00)	14,00 (4,10 - 16,00)	16,00 (4,10 - 18,00)
Heating capacity at -7°C / -15°C ⁴⁾		kW	— / —	— / —	— / —	— / —
COP ¹⁾	Nominal (Min - Max)	W/W	4,30 (5,60 - 3,16) A	5,00 (5,19 - 3,18) A	4,60 (5,19 - 3,17) A	4,30 (5,19 - 3,15) A
SCOP ²⁾		W/W	4,30 A+	4,80 A++	4,10	3,90
Pdesign at -10°C		kW	7,10	10,00	12,50	14,00
Input power heating	Nominal (Min - Max)	kW	1,86 (0,50 - 2,85)	2,24 (0,79 - 4,40)	3,04 (0,79 - 5,04)	3,72 (0,79 - 5,72)
Annual energy consumption ³⁾		kWh/a	2312	2917	—	—
Indoor unit			S-71PU2E5B	S-100PU2E5B	S-125PU2E5B	S-140PU2E5B
Air volume	Hi / Med / Lo	m ³ /min	22,00/16,00/13,00	36,00/26,00/18,00	37,00/27,00/19,00	38,00/29,00/20,00
Sound pressure ⁵⁾	Hi / Med / Lo	dB(A)	37/31/28	45/38/32	46/39/33	47/40/34
Dimension	Indoor (H x W x D)	mm	256 x 840 x 840	319 x 840 x 840	319 x 840 x 840	319 x 840 x 840
	Panel (H x W x D)	mm	33,5 x 950 x 950	33,5 x 950 x 950	33,5 x 950 x 950	33,5 x 950 x 950
Net weight	Indoor / Panel	kg	20 / 5	25 / 5	25 / 5	25 / 5
Outdoor unit			U-71PE1E8A	U-100PE1E8A	U-125PE1E8A	U-140PE1E8A
Power source		V	380/400/415	380/400/415	380/400/415	380/400/415
Recommended fuse		A	16	16	16	16
Connection indoor / outdoor		mm ²	2,5	2,5	2,5	2,5
Current	Cool	A	2,80/2,70/2,60	3,60/3,45/3,35	5,25/5,00/4,80	6,65/6,30/6,10
	Heat	A	2,90/2,80/2,70	3,45/3,30/3,20	4,75/4,50/4,35	5,80/5,55/5,35
Air volume	Cool / Heat	m ³ /min	60/60	110/95	130/110	135/120
Sound pressure	Cool / Heat (Hi)	dB(A)	48/50	52/52	53/53	54/55
Dimension	H x W x D	mm	996 x 940 x 340	1416 x 940 x 340	1416 x 940 x 340	1416 x 940 x 340
Net weight		kg	71	98	98	98
Piping connections	Liquid pipe	Inch (mm)	3/8 (9,52)	3/8 (9,52)	3/8 (9,52)	3/8 (9,52)
	Gas pipe	Inch (mm)	5/8 (15,88)	5/8 (15,88)	5/8 (15,88)	5/8 (15,88)
Pipe length range		m	5 - 50	5 - 75	5 - 75	5 - 75
Elevation difference (in/out) ⁶⁾		m	30	30	30	30
Pipe length for additional gas		m	30	30	30	30
Additional gas amount		g/m	50	50	50	50
Refrigerant (R410A)		kg/TCO ₂ Eq.	2,35/4,9068	3,40/7,0992	3,40/7,0992	3,40/7,0992
Operating range	Cool Min ~ Max	°C	-15 ~ +46	-15 ~ +46	-15 ~ +46	-15 ~ +46
	Heat Min ~ Max	°C	-20 ~ +24	-20 ~ +24	-20 ~ +24	-20 ~ +24

1) EER and COP calculation is based in accordance to EN14511. 2) For models below 12kW, the SCOP is calculated based on values of EU/626/2011. For models above 12kW, the SCOP is calculated based on values of EU/2281/2016. 3) The annual energy consumption is calculated in accordance to EU/626/2011. 4) Heating capacity is calculated including defrost factor correction. 5) The sound pressure of the units shows the value measured of a position 1m in front of the main body and 1,5m from the ground. The sound pressure is measured in accordance with Eurovent 6/C/006-97 specification. 6) When installing the outdoor unit at a higher position than the indoor unit.* Recommended fuse for the indoor 3A.



SEER and SCOP: For KIT-100PU2E5D. ECONAVI and INTERNET CONTROL: Optional.
 Compatible with all Panasonic connectivity solutions. For detailed information go to the Control Systems section.

Rating Conditions: Cooling Indoor 27°C DB / 19°C WB. Cooling Outdoor 35°C DB / 24°C WB. Heating Indoor 20°C DB. Heating Outdoor 7°C DB / 6°C WB. (DB: Dry Bulb; WB: Wet Bulb)
 Specifications subject to change without notice. For detailed information about ErP, please visit our websites www.aircon.panasonic.eu or www.ptc.panasonic.eu.

PACi STANDARD 4 WAY 90x90 CASSETTE INVERTER+ • R410A GAS



Large capacity PACi. Trusted power and high efficiency.

Thanks to advances in design and technology such as the high performance turbo fan, more efficient and silent, the nanoe™ X air cleaner, the U2 Panasonic 4 way 90x90 cassette offers high energy saving, fresh air and comfort.

Technical focus

- High performance turbo fan, path system for heat exchanger
- Lower noise in slow fan operation
- Light weight, easy piping
- Easy installation structure of the panel
- Econavi: Floor temperature and humidity sensor added. Activity amount detection and new circulator
- nanoe™ X: The first air purifier technology in commercial air conditioning

		Single Phase				
		6,0kW	7,1kW	10,0kW	12,5kW	
KIT		KIT-60PUY2E5D	KIT-71PUY2E5D	KIT-100PUY2E5D	KIT-125PUY2E5D	
Remote controller		CZ-RTC5B	CZ-RTC5B	CZ-RTC5B	CZ-RTC5B	
Cooling capacity	Nominal (Min - Max)	kW	6,00 [2,00 - 7,10]	7,10 [2,00 - 7,70]	10,00 [3,30 - 12,50]	12,50 [3,80 - 15,50]
EER ¹⁾	Nominal (Min - Max)	W/W	3,70 [8,00 - 3,23] A	3,24 [8,00 - 2,91] A	4,27 [4,29 - 3,38] A	3,16 [4,22 - 2,77] B
SEER ²⁾		W/W	7,00 A++	6,50 A++	7,60 A++	6,22
Pdesign		kW	6,00	7,10	10,00	12,50
Input power cooling	Nominal (Min - Max)	kW	1,62 [0,25 - 2,20]	2,19 [0,25 - 2,65]	2,34 [0,77 - 3,70]	3,96 [0,90 - 4,88]
Annual energy consumption ³⁾		kWh/a	300	382	461	—
Heating capacity	Nominal (Min - Max)	kW	6,00 [1,80 - 7,00]	7,10 [1,80 - 8,10]	11,20 [4,10 - 14,00]	12,50 [3,40 - 15,00]
Heating capacity at -7°C / -15°C ⁴⁾		kW	— / —	— / —	— / —	— / —
COP ¹⁾	Nominal (Min - Max)	W/W	4,20 [9,00 - 4,24] A	4,13 [9,00 - 3,68] A	5,00 [5,19 - 3,18] A	4,10 [4,66 - 3,41] A
SCOP ²⁾		W/W	4,10 A+	4,20 A+	4,80 A++	3,87
Pdesign at -10°C		kW	6,00	6,00	10,00	12,50
Input power heating	Nominal (Min - Max)	kW	1,43 [0,20 - 1,65]	1,72 [0,20 - 2,20]	2,24 [0,79 - 4,40]	3,05 [0,73 - 4,40]
Annual energy consumption ³⁾		kWh/a	2047	2002	2917	—
Indoor unit		S-60PU2E5B	S-71PU2E5B	S-100PU2E5B	S-125PU2E5B	
Air volume	Hi / Med / Lo	m ³ /min	21,00/16,00/13,00	22,00/16,00/13,00	36,0/26,00/18,00	37,00/27,00/19,00
Sound pressure ⁵⁾	Hi / Med / Lo	dB(A)	36/31/28	37/31/28	45/38/32	46/39/33
Dimension	Indoor (HxWxD)	mm	256x840x840	256x840x840	319x840x840	319x840x840
	Panel (HxWxD)	mm	33,5x950x950	33,5x950x950	33,5x950x950	33,5x950x950
Net weight	Indoor / Panel	kg	20 / 5	20 / 5	25 / 5	25 / 5
Outdoor unit		U-60PEY2E5	U-71PEY2E5	U-100PEY1E5	U-125PEY1E5	
Power source		V	220/230/240	220/230/240	220/230/240	220/230/240
Recommended fuse		A	—	—	—	30
Connection indoor / outdoor		mm ²	—	—	—	6,0
Current	Cool	A	8,00/7,60/7,30	10,70/10,30/9,85	14,80/14,20/13,60	18,80/18,00/17,20
	Heat	A	7,05/6,75/6,45	8,50/8,10/7,80	11,00/10,60/10,20	14,30/13,60/13,10
Air volume	Cool / Heat	m ³ /min	38/41	44/41	110/95	80/73
Sound pressure	Cool / Heat (Hi)	dB(A)	46/48	49/49	52/52	56/56
Dimension	HxWxD	mm	619x799x299	619x799x299	996x940x340	996x940x340
Net weight		kg	40	40	73	85
Piping connections	Liquid pipe	Inch (mm)	3/8 (9,52)	3/8 (9,52)	3/8 (9,52)	3/8 (9,52)
	Gas pipe	Inch (mm)	5/8 (15,88)	5/8 (15,88)	5/8 (15,88)	5/8 (15,88)
Pipe length range		m	3-40	3-40	5-50	5-50
Elevation difference (in/out) ⁶⁾		m	30	30	30	30
Pipe length for additional gas		m	30	30	30	30
Additional gas amount		g/m	40	40	50	50
Refrigerant (R410A)		kg/TCO ₂ Eq.	1,95/4,0716	1,95/4,0716	2,60/5,4288	3,20/6,6816
Operating range	Cool Min ~ Max	°C	-10 ~ +43	-10 ~ +43	-10 ~ +43	-10 ~ +43
	Heat Min ~ Max	°C	-15 ~ +24	-15 ~ +24	-15 ~ +24	-15 ~ +24

Accessories

CZ-RTC5B	Wired remote controller with Econavi button and datanavi
CZ-RWSU3	Wireless remote controller
CZ-RE2C2	Simplified remote controller
CZ-CNEXU1	nanoe™ X air purifying system
CZ-KPU3A	Econavi exclusive panel
PAW-WTRAY	Tray for condenser water compatible with base ground support

Accessories

PAW-GRDBSE20	Outdoor base ground support for noise and vibration absorption
PAW-WPH7	Wind protection shield for 5kW outdoor unit
PAW-WPH9	Wind protection shield for outdoor units 6/7kW Elite and 10/12,5kW Standard
PAW-WPH10	Wind protection shield for outdoor units from 10 to 14kW Elite and 14kW Standard

PACi Kits

R410A



Optional Controller. Wired remote controller CZ-RTCSB Compatible with Econavi and nanoe™ X
 Optional Controller. Wireless remote control CZ-RWSU3
 Optional Controller. Simplified remote controller CZ-REZC2
 Econavi panel: CZ-KPU3A (CZ-RTCSB is required)
 Optional nanoe™ X kit: CZ-CNEXU1 (CZ-RTCSB is required)



Group control, new circulation function

Do circulating operation when nobody there, and mix air in the whole room. Minimize temperature gap in both heating and cooling operation.

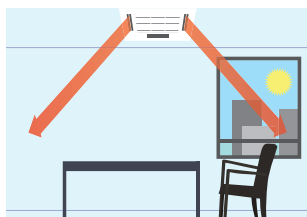

Circulation by Detecting no movement (10min.)



Indirect air flow by detecting movement

2 types of body with height difference (same as current ones)

25,6cm and 31,9cm.

Always fresh and clean air with nanoe™ X

nanoe™ X is newly developed for PACi cassette by the advanced technology of Room Air conditioning.



CZ-RTCSB and optional accessory CZ-CNEXU1 are required to use nanoe™ X function.

KIT	Three Phase				
	10,0kW	12,5kW	14,0kW		
Remote controller	KIT-100PUY2E8D CZ-RTCSB	KIT-125PUY2E8D CZ-RTCSB	KIT-140PUY2E8D CZ-RTCSB		
Cooling capacity	Nominal (Min - Max) kW	10,00 [2,70 - 11,50]	12,50 [3,80 - 13,50]	14,00 [3,30 - 15,50]	
EER ¹⁾	Nominal (Min - Max) W/W	3,16 [5,09 - 2,74] B	3,16 [4,22 - 2,77] B	3,25 [3,93 - 267] A	
SEER ²⁾	W/W	6,60 A++	6,20	6,39	
Pdesign	kW	10,00	12,50	14,00	
Input power cooling	Nominal (Min - Max) kW	3,16 [0,53 - 4,20]	3,96 [0,90 - 4,88]	4,31 [0,84 - 5,81]	
Annual energy consumption ³⁾	kWh/a	530	—	—	
Heating capacity	Nominal (Min - Max) kW	10,00 [2,10 - 13,80]	12,50 [3,40 - 15,00]	14,00 [4,10 - 16,00]	
Heating capacity at -7°C / -15°C ⁴⁾	kW	— / —	— / —	— / —	
COP ¹⁾	Nominal (Min - Max) W/W	4,15 [5,12 - 3,45] A	4,10 [4,66 - 3,41] A	4,15 [4,56 - 3,08] A	
SCOP ²⁾	W/W	4,30 A+	3,87	3,79	
Pdesign at -10°C	kW	10,00	12,50	14,00	
Input power heating	Nominal (Min - Max) kW	2,41 [0,41 - 4,00]	3,05 [0,73 - 4,40]	3,37 [0,90 - 5,20]	
Annual energy consumption ³⁾	kWh/a	3256	—	—	
Indoor unit		S-100PU2E5B	S-125PU2E5B	S-140PU2E5B	
Air volume	Hi / Med / Lo	m ³ /min	36,00/26,00/18,00	37,00/27,00/19,00	38,00/29,00/20,00
Sound pressure ⁵⁾	Hi / Med / Lo	dB(A)	45/38/32	46/39/33	47/40/34
Dimension	Indoor (H x W x D)	mm	319 x 840 x 840	319 x 840 x 840	319 x 840 x 840
	Panel (H x W x D)	mm	33,5 x 950 x 950	33,5 x 950 x 950	33,5 x 950 x 950
Net weight	Indoor / Panel	kg	25 / 5	25 / 5	25 / 5
Outdoor unit		U-100PEY1E8	U-125PEY1E8	U-140PEY1E8	
Power source	V	380/400/415	380/400/415	380/400/415	
Recommended fuse	A	16	16	16	
Connection indoor / outdoor	mm ²	2,5	2,5	2,5	
Current	Cool	A	5,00/4,75/4,60	6,20/5,90/5,70	6,75/6,40/6,20
	Heat	A	3,80/3,60/3,50	4,75/4,50/4,35	5,25/5,00/4,80
Air volume	Cool / Heat	m ³ /min	76/67	80/73	135/120
Sound pressure	Cool / Heat (Hi)	dB(A)	54/54	56/56	54/53
Dimension	H x W x D	mm	996 x 940 x 340	996 x 940 x 340	1416 x 940 x 340
Net weight	kg	73	85	98	
Piping connections	Liquid pipe	Inch (mm)	3/8 (9,52)	3/8 (9,52)	3/8 (9,52)
	Gas pipe	Inch (mm)	5/8 (15,88)	5/8 (15,88)	5/8 (15,88)
Pipe length range	m	5 - 50	5 - 50	5 - 50	
Elevation difference (in/out) ⁶⁾	m	30	30	30	
Pipe length for additional gas	m	30	30	30	
Additional gas amount	g/m	50	50	50	
Refrigerant (R410A)	kg/TCO ₂ Eq.	2,60/5,4288	3,20/6,6816	3,40/7,0992	
Operating range	Cool Min ~ Max	°C	-10 ~ +43	-10 ~ +43	-10 ~ +43
	Heat Min ~ Max	°C	-15 ~ +24	-15 ~ +24	-15 ~ +24

1) EER and COP calculation is based in accordance to EN14511. 2) For models below 12kW, the SCOP is calculated based on values of EU/626/2011. For models above 12kW, the SCOP is calculated based on values of EU/2281/2016. 3) The annual energy consumption is calculated in accordance to EU/626/2011. 4) Heating capacity is calculated including defrost factor correction. 5) The sound pressure of the units shows the value measured of a position 1m in front of the main body and 1,5m from the ground. The sound pressure is measured in accordance with Eurovent 6/C/006-97 specification. 6) When installing the outdoor unit at a higher position than the indoor unit.* Recommended fuse for the indoor 3A.



SEER and SCOP: For KIT-100PUY2E5D. ECONAVI and INTERNET CONTROL: Optional.
 Compatible with all Panasonic connectivity solutions. For detailed information go to the Control Systems section.

Rating Conditions: Cooling Indoor 27°C DB / 19°C WB. Cooling Outdoor 35°C DB / 24°C WB. Heating Indoor 20°C DB. Heating Outdoor 7°C DB / 6°C WB. (DB: Dry Bulb; WB: Wet Bulb)
 Specifications subject to change without notice. For detailed information about ErP, please visit our websites www.aircon.panasonic.eu or www.ptc.panasonic.eu.

PACi ELITE CEILING INVERTER+ • R410A GAS



This range of ceiling mounted units feature a DC fan motor for increased efficiency and reduced operating sound levels.

All the units are the same height and depth for a uniform appearance in mixed installations. A knock out is provided to allow for supplementary fresh air for improved air quality.

- Twin rotary compressor dramatically reduces vibration and noise
- DC inverter control
- Large and wide air distribution
- Industry-leading low sound levels
- Twin, Triple and Double-twin split options
- Easy connection and control of external fan or ERV using the connector PAW-FDC on the indoor unit PCB. The external device can be control by the remote control of the Panasonic indoor unit

Technical focus

- Fresh air connection possible (Outside intake duct connection port of 100mm diameter is available on the unit)
- All units just 235mm high

High heating capacity at -7°C.

			Single Phase							
			3,6kW	5,0kW	6,0kW	7,1kW	10,0kW	12,5kW	14,0kW	
KIT			KIT-36PT2E5D	KIT-50PT2E5D	KIT-60PT2E5D	KIT-71PT2E5D	KIT-100PT2E5D	KIT-125PT2E5D	KIT-140PT2E5D	
Remote controller			CZ-RTC5B	CZ-RTC5B	CZ-RTC5B	CZ-RTC5B	CZ-RTC5B	CZ-RTC5B	CZ-RTC5B	
Cooling capacity	Nominal (Min - Max)	kW	3,60(1,50 - 4,00)	5,00(1,50 - 5,60)	6,00(2,00 - 7,10)	7,10(2,50 - 8,00)	10,00(3,30 - 12,50)	12,50(3,30 - 14,00)	14,00(3,30 - 15,00)	
EER ¹⁾	Nominal (Min - Max)	W/W	4,80(6,25 - 4,49)A	3,73(6,25 - 3,41)A	3,73(8,00 - 3,16)A	3,68(5,56 - 2,88)A	3,95(3,93 - 3,25)A	3,35(3,93 - 2,88)A	3,01(3,93 - 2,65)B	
SEER ²⁾		W/W	6,70A++	6,50A++	6,80A++	6,20A++	6,70A++	5,76	5,36	
Pdesign		kW	3,60	5,00	6,00	7,10	10,00	12,50	14,00	
Input power cooling	Nominal (Min - Max)	kW	0,75(0,24 - 0,89)	1,34(0,24 - 1,64)	1,61(0,25 - 2,25)	1,93(0,45 - 2,78)	2,53(0,84 - 3,85)	3,73(0,84 - 4,86)	4,65(0,84 - 5,65)	
Annual energy consumption ³⁾		kWh/a	188	269	309	965	523	—	—	
Heating capacity	Nominal (Min - Max)	kW	4,00(1,50 - 5,00)	5,60(1,50 - 6,50)	7,00(1,80 - 8,00)	8,00(2,00 - 9,00)	11,20(4,10 - 14,00)	14,00(4,10 - 16,00)	16,00(4,10 - 18,00)	
Heating capacity at -7°C / -15°C ⁴⁾		kW	— / —	— / —	— / —	7,52 / 7,65	12,04 / 11,20	13,48 / 12,38	14,24 / 12,69	
COP ¹⁾	Nominal (Min - Max)	W/W	5,00(7,89 - 4,50)A	4,18(7,89 - 3,78)A	4,22(9,00 - 4,10)A	4,15(5,00 - 3,10)A	4,31(4,56 - 3,18)A	3,99(4,56 - 3,07)A	3,67(4,56 - 3,04)A	
SCOP ²⁾		W/W	4,30A+	4,10A+	4,10A+	4,00A+	4,30A+	3,81	3,70	
Pdesign at -10°C		kW	3,60	5,00	6,00	7,10	10,00	12,50	14,00	
Input power heating	Nominal (Min - Max)	kW	0,80(0,19 - 1,11)	1,34(0,19 - 1,72)	1,66(0,20 - 1,95)	1,93(0,40 - 2,90)	2,60(0,90 - 4,40)	3,51(0,90 - 5,21)	4,36(0,90 - 5,93)	
Annual energy consumption ³⁾		kWh/a	1172	1707	2050	2485	3256	—	—	
Indoor unit			S-36PT2E5B	S-50PT2E5B	S-60PT2E5B	S-71PT2E5B	S-100PT2E5B	S-125PT2E5B	S-140PT2E5B	
Air volume	Hi / Med / Lo	m ³ /min	14,00/12,00/10,50	15,00/12,50/10,50	20,00/17,00/14,50	21,00/18,00/15,50	30,00/25,00/23,00	34,00/28,00/24,00	35,00/29,00/25,00	
Sound pressure ⁵⁾	Hi / Med / Lo	dB(A)	36/32/29	37/33/29	38/34/30	39/35/31	42/37/35	46/40/36	47/41/37	
Dimension	HxWxD	mm	235x960x690	235x960x690	235x1275x690	235x1275x690	235x1590x690	235x1590x690	235x1590x690	
Net weight		kg	27	27	33	33	40	40	40	
Outdoor unit			U-36PE2E5A	U-50PE2E5A	U-60PE2E5A	U-71PE1E5A	U-100PE1E5A	U-125PE1E5A	U-140PE1E5A	
Power source		V	220/230/240	220/230/240	220/230/240	220/230/240	220/230/240	220/230/240	220/230/240	
Recommended fuse		A	—	—	—	20	25	30	16	
Connection indoor / outdoor		mm ²	—	—	—	2,5	4,0	6,0	2,5	
Current	Cool	A	3,55/3,40/3,25	6,30/6,00/5,75	7,90/7,50/7,20	9,00/8,70/8,40	11,50/11,10/10,60	17,00/16,40/15,80	21,20/20,50/19,80	
	Heat	A	3,80/3,65/3,50	6,35/6,10/5,80	8,15/7,80/7,45	8,90/8,60/8,30	11,80/11,40/11,00	16,00/15,40/14,90	19,80/19,20/18,50	
Air volume	Cool / Heat	m ³ /min	38/38	38/41	38/41	60/60	110/95	130/110	135/120	
Sound pressure	Cool / Heat (Hi)	dB(A)	45/46	46/48	46/49	48/50	52/52	53/53	54/55	
Dimension	HxWxD	mm	619x799x299	619x799x299	619x799x299	996x940x340	1416x940x340	1416x940x340	1416x940x340	
Net weight		kg	39	39	40	69	98	98	98	
Piping connections	Liquid pipe	Inch (mm)	1/4(6,35)	1/4(6,35)	3/8(9,52)	3/8(9,52)	3/8(9,52)	3/8(9,52)	3/8(9,52)	
	Gas pipe	Inch (mm)	1/2(12,70)	1/2(12,70)	5/8(15,88)	5/8(15,88)	5/8(15,88)	5/8(15,88)	5/8(15,88)	
Pipe length range		m	3-40	3-40	3-40	5-50	5-75	5-75	5-75	
Elevation difference (in/out) ⁶⁾		m	30	30	30	30	30	30	30	
Pipe length for additional gas		m	30	30	30	30	30	30	30	
Additional gas amount		g/m	20	20	40	50	50	50	50	
Refrigerant (R410A)		kg/TCO ₂ Eq.	1,40/2,9232	1,40/2,9232	1,95/4,0716	2,35/4,9068	3,40/7,0992	3,40/7,0992	3,40/7,0992	
Operating range	Cool Min ~ Max	°C	-15 ~ +46	-15 ~ +46	-15 ~ +46	-15 ~ +46	-15 ~ +46	-15 ~ +46	-15 ~ +46	
	Heat Min ~ Max	°C	-20 ~ +24	-20 ~ +24	-20 ~ +24	-20 ~ +24	-20 ~ +24	-20 ~ +24	-20 ~ +24	

Accessories

CZ-RTC5B	Wired remote controller with Econavi button and datanavi
CZ-RWST3N	Wireless remote controller
CZ-RE2C2	Simplified remote controller
PAW-WTRAY	Tray for condenser water compatible with base ground support
PAW-GRDBSE20	Outdoor base ground support for noise and vibration absorption
PAW-GRDSTD40	Outdoor elevation platform 400x900x400mm

Accessories

PAW-WPH7	Wind protection shield for 5kW outdoor unit
PAW-WPH9	Wind protection shield for outdoor units 6/7kW Elite and 10/12,5kW Standard
PAW-WPH10	Wind protection shield for outdoor units from 10 to 14kW Elite and 14kW Standard

PACi Kits

R410A



Further comfort improvement

The wide air discharge opening expands the air flow to the left and the right. The unpleasant feeling caused when the air flow directly hits the human body is prevented by the "Draft prevention position", which changes the swing width, so that the degree of comfort is increased.

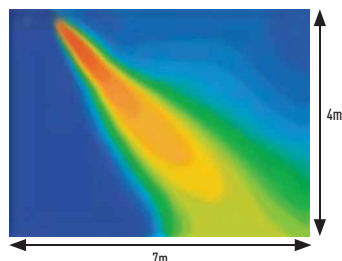

Further comfort improvement with airflow distribution

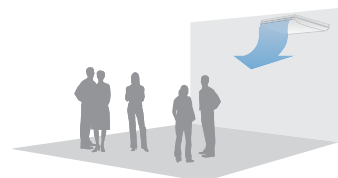

Air distribution is altered depending on the operational mode of the unit

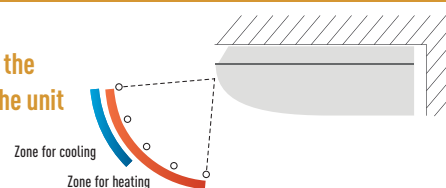

			Three Phase			
			7,1kW	10,0kW	12,5kW	14,0kW
KIT			KIT-71PT2E8D	KIT-100PT2E8D	KIT-125PT2E8D	KIT-140PT2E8D
Remote controller			CZ-RTCSB	CZ-RTCSB	CZ-RTCSB	CZ-RTCSB
Cooling capacity	Nominal (Min - Max)	kW	7,10 (2,50 - 8,00)	10,00 (3,30 - 12,50)	12,50 (3,30 - 14,00)	14,00 (3,30 - 15,00)
EER ¹⁾	Nominal (Min - Max)	W/W	3,68 (5,56 - 2,88) A	3,95 (3,93 - 3,25) A	3,35 (3,93 - 2,88) A	3,01 (3,93 - 2,65) B
SEER ²⁾		W/W	5,90A+	6,60A++	5,74	5,34
Pdesign		kW	7,10	10,00	12,50	14,00
Input power cooling	Nominal (Min - Max)	kW	1,93 (0,45 - 2,78)	2,53 (0,84 - 3,85)	3,73 (0,84 - 4,86)	4,65 (0,84 - 5,65)
Annual energy consumption ³⁾		kWh/a	421	531	—	—
Heating capacity	Nominal (Min - Max)	kW	8,00 (2,00 - 9,00)	11,20 (4,10 - 14,00)	14,00 (4,10 - 16,00)	16,00 (4,10 - 18,00)
Heating capacity at -7°C / -15°C ⁴⁾		kW	7,52 / 7,65	12,04 / 11,20	13,48 / 12,38	14,24 / 12,69
COP ¹⁾	Nominal (Min - Max)	W/W	4,15 (5,00 - 3,10) A	4,31 (4,56 - 3,18) A	3,99 (4,56 - 3,07) A	3,67 (4,56 - 3,04) A
SCOP ²⁾		W/W	4,00A+	4,30A+	3,81	3,70
Pdesign at -10°C		kW	7,10	10,00	12,50	14,00
Input power heating	Nominal (Min - Max)	kW	1,93 (0,40 - 2,90)	2,60 (0,90 - 4,40)	3,51 (0,90 - 5,21)	4,36 (0,90 - 5,93)
Annual energy consumption ³⁾		kWh/a	2485	3256	—	—
Indoor unit			S-71PT2E5B	S-100PT2E5B	S-125PT2E5B	S-140PT2E5B
Air volume	Hi / Med / Lo	m ³ /min	21,00 / 18,00 / 15,50	30,00 / 25,00 / 23,00	34,00 / 28,00 / 24,00	35,00 / 29,00 / 25,00
Sound pressure ⁵⁾	Hi / Med / Lo	dB(A)	39 / 35 / 31	42 / 37 / 35	46 / 40 / 36	47 / 41 / 37
Dimension	H x W x D	mm	235 x 1275 x 690	235 x 1590 x 690	235 x 1590 x 690	235 x 1590 x 690
Net weight		kg	33	40	40	40
Outdoor unit			U-71PE1E8A	U-100PE1E8A	U-125PE1E8A	U-140PE1E8A
Power source		V	380 / 400 / 415	380 / 400 / 415	380 / 400 / 415	380 / 400 / 415
Recommended fuse		A	16	16	16	16
Connection indoor / outdoor		mm ²	2,5	2,5	2,5	2,5
Current	Cool	A	3,00 / 2,90 / 2,80	3,95 / 3,75 / 3,65	5,85 / 5,55 / 5,35	7,30 / 6,95 / 6,70
	Heat	A	3,00 / 2,90 / 2,80	4,05 / 3,85 / 3,75	5,50 / 5,20 / 5,05	6,85 / 6,50 / 6,25
Air volume	Cool / Heat	m ³ /min	60 / 60	110 / 95	130 / 110	135 / 120
Sound pressure	Cool / Heat (Hi)	dB(A)	48 / 50	52 / 52	53 / 53	54 / 55
Dimension	H x W x D	mm	996 x 940 x 340	1416 x 940 x 340	1416 x 940 x 340	1416 x 940 x 340
Net weight		kg	71	98	98	98
Piping connections	Liquid pipe	Inch (mm)	3/8 (9,52)	3/8 (9,52)	3/8 (9,52)	3/8 (9,52)
	Gas pipe	Inch (mm)	5/8 (15,88)	5/8 (15,88)	5/8 (15,88)	5/8 (15,88)
Pipe length range		m	5 - 50	5 - 75	5 - 75	5 - 75
Elevation difference (in/out) ⁶⁾		m	30	30	30	30
Pipe length for additional gas		m	30	30	30	30
Additional gas amount		g/m	50	50	50	50
Refrigerant (R410A)		kg / TCO ₂ Eq.	2,35 / 4,9068	3,40 / 7,0992	3,40 / 7,0992	3,40 / 7,0992
Operating range	Cool Min ~ Max	°C	-15 ~ +46	-15 ~ +46	-15 ~ +46	-15 ~ +46
	Heat Min ~ Max	°C	-20 ~ +24	-20 ~ +24	-20 ~ +24	-20 ~ +24

1) EER and COP calculation is based in accordance to EN14511. 2) For models below 12kW, the SCOP is calculated based on values of EU/626/2011. For models above 12kW, the SCOP is calculated based on values of EU/2281/2016. 3) The annual energy consumption is calculated in accordance to EU/626/2011. 4) Heating capacity is calculated including defrost factor correction. 5) The sound pressure of the units shows the value measured of a position 1m in front of the main body and 1,5m from the ground. The sound pressure is measured in accordance with Eurovent 6/C/006-97 specification. 6) When installing the outdoor unit at a higher position than the indoor unit.* Recommended fuse for the indoor 3A.



SEER and SCOP: For KIT-60PT2E5D. INTERNET CONTROL: Optional.
Compatible with all Panasonic connectivity solutions. For detailed information go to the Control Systems section.

Rating Conditions: Cooling Indoor 27°C DB / 19°C WB. Cooling Outdoor 35°C DB / 24°C WB. Heating Indoor 20°C DB. Heating Outdoor 7°C DB / 6°C WB. (DB: Dry Bulb; WB: Wet Bulb)
Specifications subject to change without notice. For detailed information about ErP, please visit our websites www.aircon.panasonic.eu or www.gtc.panasonic.eu.

PACi STANDARD CEILING INVERTER+

• R410A GAS



This range of ceiling mounted units feature a DC fan motor for increased efficiency and reduced operating sound levels.

All the units are the same height and depth for a uniform appearance in mixed installations. A knock out is provided to allow for supplementary fresh air for improved air quality.

Technical focus

- Fresh air connection possible (Outside intake duct connection port of 100mm diameter is available on the unit)
- All units just 235mm high

- Twin rotary compressor dramatically reduces vibration and noise
- DC inverter control
- Large and wide air distribution
- Industry-leading low sound levels
- Twin, Triple and Double-twin split options
- Easy connection and control of external fan or ERV using the connector PAW-FDC on the indoor unit PCB. The external device can be control by the remote control of the Panasonic indoor unit

High heating capacity at -7°C.

		Single Phase				
KIT		6,0kW	7,1kW	10,0kW	12,5kW	
Remote controller		KIT-60PTY2E5D CZ-RTC5B	KIT-71PTY2E5D CZ-RTC5B	KIT-100PTY2E5D CZ-RTC5B	KIT-125PTY2E5D CZ-RTC5B	
Cooling capacity	Nominal (Min - Max)	kW	6,00 [2,00 - 7,10]	7,10 [2,00 - 7,70]	10,00 [2,70 - 11,50]	12,50 [3,80 - 13,50]
EER ¹⁾	Nominal (Min - Max)	W/W	3,68 [8,00 - 3,16]A	3,21 [8,00 - 2,91]A	3,01 [5,09 - 2,65]	3,01 [4,22 - 2,62]B
SEER ²⁾		W/W	6,70A++	6,10A++	6,10A++	5,26
Pdesign		kW	6,00	7,10	10,00	12,50
Input power cooling	Nominal (Min - Max)	kW	1,63 [0,25 - 2,25]	2,21 [0,25 - 2,65]	3,32 [0,53 - 4,34]	4,15 [0,90 - 5,16]
Annual energy consumption ³⁾		kWh/a	313	407	574	—
Heating capacity	Nominal (Min - Max)	kW	6,00 [1,80 - 7,00]	7,10 [1,80 - 8,10]	10,00 [2,10 - 13,80]	12,50 [3,40 - 15,00]
Heating capacity at -7°C / -15°C ⁴⁾		kW	— / —	— / —	9,97 / 8,43	10,97 / 9,03
COP ¹⁾	Nominal (Min - Max)	W/W	4,35 [9,00 - 4,38]A	4,23 [9,00 - 3,77]A	3,85 [5,12 - 3,45]A	3,85 [4,66 - 3,41]A
SCOP ²⁾		W/W	4,00A+	4,00A+	3,90A	3,58
Pdesign at -10°C		kW	6,00	6,00	10,00	12,50
Input power heating	Nominal (Min - Max)	kW	1,38 [0,20 - 1,60]	1,68 [0,20 - 2,15]	2,60 [0,41 - 4,00]	3,25 [0,73 - 4,40]
Annual energy consumption ³⁾		kWh/a	2100	2100	3590	—
Indoor unit		S-60PT2E5B	S-71PT2E5B	S-100PT2E5B	S-125PT2E5B	
Air volume	Hi / Med / Lo	m ³ /min	20,00 / 17,00 / 14,50	21,00 / 18,00 / 15,50	30,00 / 25,00 / 23,00	34,00 / 28,00 / 24,00
Sound pressure ⁵⁾	Hi / Med / Lo	dB(A)	38 / 34 / 30	39 / 35 / 31	42 / 37 / 35	46 / 40 / 36
Dimension	HxWxD	mm	235 x 1275 x 690	235 x 1275 x 690	235 x 1590 x 690	235 x 1590 x 690
Net weight		kg	33	33	40	40
Outdoor unit		U-60PEY2E5	U-71PEY2E5	U-100PEY1E5	U-125PEY1E5	
Power source		V	220 / 230 / 240	220 / 230 / 240	220 / 230 / 240	220 / 230 / 240
Recommended fuse		A	—	—	25	30
Connection indoor / outdoor		mm ²	—	—	4	6
Current	Cool	A	8,00 / 7,60 / 7,30	10,80 / 10,30 / 9,85	15,60 / 15,00 / 14,40	19,70 / 18,90 / 18,10
	Heat	A	6,70 / 6,45 / 6,15	8,20 / 7,85 / 7,50	11,90 / 11,50 / 11,10	15,20 / 14,60 / 13,90
Air volume	Cool / Heat	m ³ /min	38 / 41	44 / 41	110 / 95	80 / 73
Sound pressure	Cool / Heat (Hi)	dB(A)	46 / 48	49 / 49	52 / 52	56 / 56
Dimension	HxWxD	mm	619 x 799 x 299	619 x 799 x 299	996 x 940 x 340	996 x 940 x 340
Net weight		kg	40	40	73	85
Piping connections	Liquid pipe	Inch (mm)	3/8 [9,52]	3/8 [9,52]	3/8 [9,52]	3/8 [9,52]
	Gas pipe	Inch (mm)	5/8 [15,88]	5/8 [15,88]	5/8 [15,88]	5/8 [15,88]
Pipe length range		m	3 ~ 40	3 ~ 40	5 ~ 50	5 ~ 50
Elevation difference (in/out) ⁶⁾		m	30	30	30	30
Pipe length for additional gas		m	30	30	30	30
Additional gas amount		g/m	40	40	50	50
Refrigerant (R410A)		kg / TCO ₂ Eq.	1,95 / 4,0716	1,95 / 4,0716	2,60 / 5,4288	3,20 / 6,6816
Operating range	Cool Min ~ Max	°C	-10 ~ +43	-10 ~ +43	-10 ~ +43	-10 ~ +43
	Heat Min ~ Max	°C	-15 ~ +24	-15 ~ +24	-15 ~ +24	-15 ~ +24

Accessories

CZ-RTC5B	Wired remote controller with Econavi button and datanavi
CZ-RWST3N	Wireless remote controller
CZ-RE2C2	Simplified remote controller
PAW-WTRAY	Tray for condenser water compatible with base ground support
PAW-GRDBSE20	Outdoor base ground support for noise and vibration absorption
PAW-GRDSTD40	Outdoor elevation platform 400 x 900 x 400mm

Accessories

PAW-WPH7	Wind protection shield for 5kW outdoor unit
PAW-WPH9	Wind protection shield for outdoor units 6/7kW Elite and 10/12,5kW Standard
PAW-WPH10	Wind protection shield for outdoor units from 10 to 14kW Elite and 14kW Standard

PACi Kits

R410A



Further comfort improvement

The wide air discharge opening expands the air flow to the left and the right. The unpleasant feeling caused when the air flow directly hits the human body is prevented by the "Draft prevention position", which changes the swing width, so that the degree of comfort is increased.

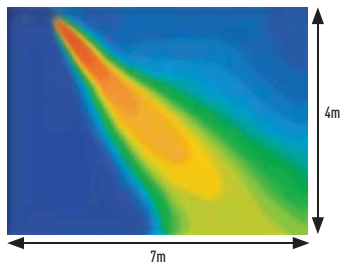

Further comfort improvement with airflow distribution

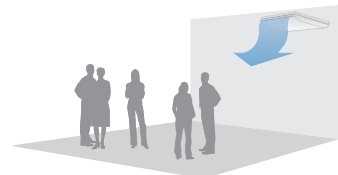

Air distribution is altered depending on the operational mode of the unit

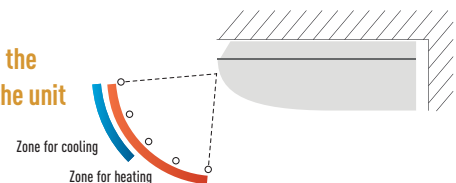

KIT	Three Phase		
	10,0kW	12,5kW	14,0kW
Remote controller	KIT-100PTY2E8D	KIT-125PTY2E8D	KIT-140PTY2E8D
	CZ-RTCSB	CZ-RTCSB	CZ-RTCSB
Cooling capacity	Nominal [Min - Max] kW	10,00 [2,70 - 11,50]	12,50 [3,80 - 13,50]
EER ¹⁾	Nominal [Min - Max] W/W	3,01 [5,09 - 2,65] B	3,01 [4,22 - 2,62] B
SEER ²⁾	W/W	6,00 A+	5,24
Pdesign	kW	10,00	12,50
Input power cooling	Nominal [Min - Max] kW	3,32 [0,53 - 4,34]	4,15 [0,90 - 5,16]
Annual energy consumption ³⁾	kWh/a	584	—
Heating capacity	Nominal [Min - Max] kW	10,00 [2,10 - 13,80]	12,50 [3,40 - 15,00]
Heating capacity at -7°C / -15°C ⁴⁾	kW	9,97/8,43	10,97/9,03
COP ¹⁾	Nominal [Min - Max] W/W	3,85 [5,12 - 3,45] A	3,85 [4,66 - 3,41] A
SCOP ²⁾	W/W	3,90 A	3,58
Pdesign at -10°C	kW	10,00	12,50
Input power heating	Nominal [Min - Max] kW	2,60 [0,41 - 4,00]	3,25 [0,73 - 4,40]
Annual energy consumption ³⁾	kWh/a	3590	—
Indoor unit	S-100PT2E5B	S-125PT2E5B	S-140PT2E5B
Air volume	Hi / Med / Lo	m ³ /min	30,00/25,00/23,00
Sound pressure ⁵⁾	Hi / Med / Lo	dB(A)	42/37/35
Dimension	H x W x D	mm	235 x 1590 x 690
Net weight		kg	40
Outdoor unit	U-100PEY1E8	U-125PEY1E8	U-140PEY1E8
Power source	V	380/400/415	380/400/415
Recommended fuse	A	16	16
Connection indoor / outdoor	mm ²	2,5	2,5
Current	Cool / Heat	A	5,30/5,05/4,85
		A	4,10/3,90/3,75
Air volume	Cool / Heat	m ³ /min	76/67
Sound pressure	Cool / Heat (Hi)	dB(A)	54/54
Dimension	H x W x D	mm	996 x 940 x 340
Net weight		kg	73
Piping connections	Liquid pipe	Inch (mm)	3/8 [9,52]
	Gas pipe	Inch (mm)	5/8 [15,88]
Pipe length range	m	5 - 50	5 - 50
Elevation difference (in/out) ⁶⁾	m	30	30
Pipe length for additional gas	m	30	30
Additional gas amount	g/m	50	50
Refrigerant (R410A)	kg / TCO ₂ Eq.	2,60/5,4288	3,20/6,6816
Operating range	Cool Min ~ Max	°C	-10 ~ +43
	Heat Min ~ Max	°C	-15 ~ +24

1) EER and COP calculation is based in accordance to EN14511. 2) For models below 12kW, the SCOP is calculated based on values of EU/626/2011. For models above 12kW, the SCOP is calculated based on values of EU/2281/2016. 3) The annual energy consumption is calculated in accordance to EU/626/2011. 4) Heating capacity is calculated including defrost factor correction. 5) The sound pressure of the units shows the value measured of a position 1m in front of the main body and 1,5m from the ground. The sound pressure is measured in accordance with Eurovent 6/C/006-97 specification. 6) When installing the outdoor unit at a higher position than the indoor unit.* Recommended fuse for the indoor 3A.



SEER and SCOP: For KIT-60PTY2E5D. INTERNET CONTROL: Optional.
Compatible with all Panasonic connectivity solutions. For detailed information go to the Control Systems section.

Rating Conditions: Cooling Indoor 27°C DB / 19°C WB. Cooling Outdoor 35°C DB / 24°C WB. Heating Indoor 20°C DB. Heating Outdoor 7°C DB / 6°C WB. (DB: Dry Bulb; WB: Wet Bulb)
Specifications subject to change without notice. For detailed information about ErP, please visit our websites www.aircon.panasonic.eu or www.ptc.panasonic.eu.

PACi ELITE HIGH STATIC PRESSURE HIDE AWAY INVERTER+ • R410A GAS



The ducted systems are the ideal solution for flexible, concealed air conditioning and the optional 200mm spigots ensure simple, hassle-free connection to spiral ductwork.

High heating capacity at -7°C.

Technical focus

- Quiet operation from 25dB(A)
- Auto restart after power failure
- Auto changeover
- Twin, triple and double-twin split options
- DC FAN for better efficiency and control
- Built in drain pump
- Easy connection and control of external fan or ERV using the connector PAW-FDC on the indoor unit PCB. The external device can be control by the remote control of the Panasonic indoor unit

			Single Phase								
			3,6kW	5,0kW	6,0kW	7,1kW	10,0kW	12,5kW	14,0kW		
KIT			KIT-36PF1E5D	KIT-50PF1E5D	KIT-60PF1E5D	KIT-71PF1E5D	KIT-100PF1E5D	KIT-125PF1E5D	KIT-140PF1E5D		
Remote controller			CZ-RTC5B	CZ-RTC5B	CZ-RTC5B	CZ-RTC5B	CZ-RTC5B	CZ-RTC5B	CZ-RTC5B		
Cooling capacity	Nominal (Min - Max)	kW	3,60(1,50 - 4,00)	5,00(1,50 - 5,60)	6,00(2,00 - 7,10)	7,10(2,50 - 8,00)	10,00(3,30 - 12,50)	12,50(3,30 - 14,00)	14,00(3,30 - 15,50)		
EER ¹⁾	Nominal (Min - Max)	W/W	4,44(5,17 - 4,00)A	3,85(5,17 - 3,50)A	3,64(5,97 - 3,02)A	3,84(4,72 - 3,02)A	4,10(3,93 - 3,38)A	3,50(3,93 - 3,04)A	3,25(3,93 - 2,58)A		
SEER ²⁾		W/W	5,70A+	5,70A+	6,10A++	6,40A++	5,80A+	5,57	5,41		
Pdesign		kW	3,60	5,00	6,00	7,10	10,00	12,50	14,00		
Input power cooling	Nominal (Min - Max)	kW	0,81(0,29 - 1,00)	1,30(0,29 - 1,60)	1,65(0,34 - 2,35)	1,85(0,53 - 2,65)	2,44(0,84 - 3,70)	3,57(0,84 - 4,60)	4,31(0,84 - 6,00)		
Annual energy consumption ³⁾		kWh/a	221	307	344	388	603	—	—		
Heating capacity	Nominal (Min - Max)	kW	4,00(1,50 - 5,00)	5,60(1,50 - 6,50)	7,00(1,80 - 8,00)	8,00(2,00 - 9,00)	11,20(4,10 - 14,00)	14,00(4,10 - 16,00)	16,00(4,10 - 18,00)		
Heating capacity at -7°C / -15°C ⁴⁾		kW	— / —	— / —	— / —	— / —	— / —	— / —	12,32 / —		
COP ¹⁾	Nominal (Min - Max)	W/W	4,55(6,25 - 4,17)A	4,03(6,25 - 3,71)A	4,00(6,32 - 3,81)A	3,85(4,17 - 3,10)A	4,31(4,56 - 3,18)A	4,02(4,56 - 3,08)A	3,60(4,56 - 3,05)A		
SCOP ²⁾		W/W	3,90A	3,90A	4,00A+	4,00A+	3,80A	3,72	3,63		
Pdesign at -10°C		kW	3,60	4,00	6,00	7,10	10,00	12,50	14,00		
Input power heating	Nominal (Min - Max)	kW	0,88(0,24 - 1,20)	1,39(0,24 - 1,75)	1,75(0,29 - 2,10)	2,08(0,48 - 2,90)	2,60(0,90 - 4,40)	3,48(0,90 - 5,20)	4,44(0,90 - 5,90)		
Annual energy consumption ³⁾		kWh/a	1292	1436	2100	2485	3684	—	—		
Indoor unit			S-36PF1E5B	S-50PF1E5B	S-60PF1E5B	S-71PF1E5B	S-100PF1E5B	S-125PF1E5B	S-140PF1E5B		
External static pressure ⁵⁾	Nominal (Min - Max)	Pa	70(10 - 150)	70(10 - 150)	70(10 - 150)	70(10 - 150)	100(10 - 150)	100(10 - 150)	100(10 - 150)		
Air volume	Hi / Med / Lo	m ³ /min	14,00/13,00/10,00	16,00/15,00/12,00	21,00/19,00/15,00	21,00/19,00/15,00	32,00/26,00/21,00	34,00/29,00/23,00	36,00/32,00/25,00		
Sound pressure ⁶⁾	Hi / Med / Lo	dB(A)	33/29/25	34/30/26	35/32/26	35/32/26	38/34/31	39/35/32	40/36/33		
Dimension	H x W x D	mm	290 x 800 x 700	290 x 800 x 700	290 x 1000 x 700	290 x 1000 x 700	290 x 1400 x 700	290 x 1400 x 700	290 x 1400 x 700		
Net weight		kg	28	28	33	33	45	45	45		
Outdoor unit			U-36PE2E5A	U-50PE2E5A	U-60PE2E5A	U-71PE1E5A	U-100PE1E5A	U-125PE1E5A	U-140PE1E5A		
Power source		V	220/230/240	220/230/240	220/230/240	220/230/240	220/230/240	220/230/240	220/230/240		
Recommended fuse		A	—	—	—	20	25	30	16		
Connection indoor / outdoor		mm ²	—	—	—	2,5	4,0	6,0	2,5		
Current	Cool	A	3,70/3,50/3,40	5,80/5,60/5,30	7,70/7,40/7,10	8,90/8,60/8,30	11,00/10,60/10,30	16,60/15,90/15,30	20,10/19,30/18,60		
	Heat	A	4,05/3,85/3,70	6,30/6,05/5,80	8,25/7,85/7,55	9,90/9,50/9,20	11,60/11,20/10,70	16,30/15,80/15,10	19,90/19,10/18,40		
Air volume	Cool / Heat	m ³ /min	38/38	38/41	38/41	60/60	110/95	130/110	135/120		
Sound pressure	Cool / Heat (Hi)	dB(A)	45/46	46/48	46/49	48/50	52/52	53/53	54/55		
Dimension	H x W x D	mm	619 x 799 x 299	619 x 799 x 299	619 x 799 x 299	996 x 940 x 340	1416 x 940 x 340	1416 x 940 x 340	1416 x 940 x 340		
Net weight		kg	39	39	40	69	98	98	98		
Piping connections	Liquid pipe	Inch (mm)	1/4(6,35)	1/4(6,35)	3/8(9,52)	3/8(9,52)	3/8(9,52)	3/8(9,52)	3/8(9,52)		
	Gas pipe	Inch (mm)	1/2(12,70)	1/2(12,70)	5/8(15,88)	5/8(15,88)	5/8(15,88)	5/8(15,88)	5/8(15,88)		
Pipe length range		m	3 - 40	3 - 40	3 - 40	5 - 50	5 - 75	5 - 75	5 - 75		
Elevation difference (in/out) ⁷⁾		m	30	30	30	30	30	30	30		
Pipe length for additional gas		m	30	30	30	30	30	30	30		
Additional gas amount		g/m	20	20	40	50	50	50	50		
Refrigerant (R410A)		kg/TCO ₂ Eq.	1,40/2,9232	1,40/2,9232	1,95/4,0716	2,35/4,9068	3,40/7,0992	3,40/7,0992	3,40/7,0992		
Operating range	Cool Min ~ Max	°C	-15 ~ +46	-15 ~ +46	-15 ~ +46	-15 ~ +46	-15 ~ +46	-15 ~ +46	-15 ~ +46		
	Heat Min ~ Max	°C	-20 ~ +24	-20 ~ +24	-20 ~ +24	-20 ~ +24	-20 ~ +24	-20 ~ +24	-20 ~ +24		

Accessories

CZ-RTC5B	Wired remote controller with Econavi button and datanavi
CZ-RWSK2 + CZ-RWSC3	Wireless remote controller
CZ-RE2C2	Simplified remote controller
PAW-WTRAY	Tray for condenser water compatible with base ground support
PAW-GRDBSE20	Outdoor base ground support for noise and vibration absorption
PAW-GRDSTD40	Outdoor elevation platform 400 x 900 x 400mm

Accessories

CZ-56DAF2	Air Outlet Plenum S...PF1E5B 36, 45 & 50
CZ-90DAF2	Air Outlet Plenum S...PF1E5B 60 & 71
CZ-160DAF2	Air Outlet Plenum S...PF1E5B 100, 125 & 140
CZ-DUMPA90MF2	Air Inlet Plenum S...PF1E5B 60 & 71
CZ-DUMPA160MF2	Air Inlet Plenum S...PF1E5B 100, 125 & 140

PACi Kits

R410A



Optional Controller. Wired remote controller CZ-RTCSB Compatible with Econavi
 Optional Controller. Wireless remote controller CZ-RWSK2 + CZ-RWSC3
 Optional Controller. Simplified remote controller CZ-REZC2
 Optional Econavi Sensor. CZ-CENSC1



Air Outlet Plenum (without regulation adaptor)		
	Diameters	Model
36, 45 & 50	2xØ 200	CZ-56DAF2
60 & 71	3xØ 200	CZ-90DAF2
100, 125 & 140	4xØ 200	CZ-160DAF2

Air Inlet Plenum		
	Diameters	Model
60 & 71	2xØ 250	CZ-DUMPA90MF2
100, 125 & 140	4xØ 200	CZ-DUMPA160MF2

Standardized height of 290mm for all models. Height standardization enables easy and uniform installation for models with different capacities.

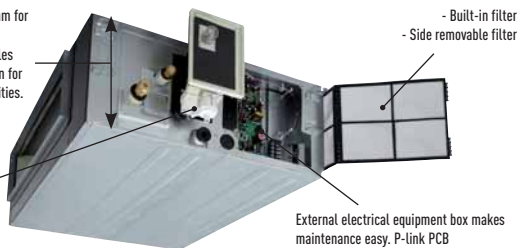

Built-in Drain pump (DC motor pump)

External electrical equipment box makes maintenance easy. P-link PCB

The static pressure outside the unit can be increased up to 150 Pa

Type		36	45	50	60	71	100	125	140
Standard	Pa	70	70	70	70	70	100	100	100
Maximum available setting	Pa	150	150	150	150	150	150	150	150

More powerful drain pump

Using a high-lift drain pump, drain piping can be elevated up to 785mm from the base of the unit.

Three Phase

KIT	7,1kW				10,0kW				12,5kW				14,0kW			
	Remote controller		KIT-71PF1E8D CZ-RTCSB		KIT-100PF1E8D CZ-RTCSB		KIT-125PF1E8D CZ-RTCSB		KIT-140PF1E8D CZ-RTCSB							
Cooling capacity	Nominal (Min - Max)	kW	7,10 (3,20 - 8,00)		10,00 (3,30 - 12,50)		12,50 (3,30 - 14,00)		14,00 (3,30 - 15,50)							
EER ¹⁾	Nominal (Min - Max)	W/W	3,84 (5,0 - 3,02)A		4,10 (3,93 - 3,38)A		3,50 (3,93 - 3,04)A		3,25 (3,93 - 2,58)A							
SEER ²⁾		W/W	6,00A+		5,70A+		5,55		5,40							
Pdesign		kW	7,10		10,00		12,50		14,00							
Input power cooling	Nominal (Min - Max)	kW	1,85 (0,64 - 2,65)		2,44 (0,84 - 3,70)		3,57 (0,84 - 4,60)		4,31 (0,84 - 6,00)							
Annual energy consumption ³⁾		kWh/a	414		614		—		—							
Heating capacity	Nominal (Min - Max)	kW	8,00 (2,80 - 9,00)		11,20 (4,10 - 14,00)		14,00 (4,10 - 16,00)		16,00 (4,10 - 18,00)							
Heating capacity at -7°C / -15°C ⁴⁾		kW	— / —		— / —		— / —		12,32 / —							
COP ¹⁾	Nominal (Min - Max)	W/W	3,85 (4,83 - 3,10)A		4,31 (4,56 - 3,18)A		4,02 (4,56 - 3,08)A		3,60 (4,56 - 3,05)A							
SCOP ²⁾		W/W	3,90A		3,80A		3,72		3,63							
Pdesign at -10°C		kW	7,10		10,00		12,50		14,00							
Input power heating	Nominal (Min - Max)	kW	2,08 (0,58 - 2,90)		2,60 (0,90 - 4,40)		3,48 (0,90 - 5,20)		4,44 (0,90 - 5,90)							
Annual energy consumption ³⁾		kWh/a	2548		3684		—		—							
Indoor unit			S-71PF1E5B		S-100PF1E5B		S-125PF1E5B		S-140PF1E5B							
External static pressure ⁵⁾	Nominal (Min - Max)	Pa	70 (10 - 150)		100 (10 - 150)		100 (10 - 150)		100 (10 - 150)							
Air volume	Hi / Med / Lo	m ³ /min	21,00 / 19,00 / 15,00		32,00 / 26,00 / 21,00		34,00 / 29,00 / 23,00		36,00 / 32,00 / 25,00							
Sound pressure ⁶⁾	Hi / Med / Lo	dB(A)	35 / 32 / 26		38 / 34 / 31		39 / 35 / 32		40 / 36 / 33							
Dimension	H x W x D	mm	290 x 1000 x 700		290 x 1400 x 700		290 x 1400 x 700		290 x 1400 x 700							
Net weight		kg	33		45		45		45							
Outdoor unit			U-71PE1E8A		U-100PE1E8A		U-125PE1E8A		U-140PE1E8A							
Power source		V	380 / 400 / 415		380 / 400 / 415		380 / 400 / 415		380 / 400 / 415							
Recommended fuse		A	16		16		16		16							
Connection indoor / outdoor		mm ²	2,5		2,5		2,5		2,5							
Current	Cool	A	2,75 / 2,65 / 2,60		3,68 / 3,53 / 3,43		5,52 / 5,29 / 5,12		6,69 / 6,42 / 6,18							
	Heat	A	3,10 / 3,00 / 2,90		3,86 / 3,70 / 3,58		5,44 / 5,26 / 5,05		6,64 / 6,35 / 6,15							
Air volume	Cool / Heat	m ³ /min	60 / 60		110 / 95		130 / 110		135 / 120							
Sound pressure	Cool / Heat (Hi)	dB(A)	48 / 50		52 / 52		53 / 53		54 / 55							
Dimension	H x W x D	mm	996 x 940 x 340		1416 x 940 x 340		1416 x 940 x 340		1416 x 940 x 340							
Net weight		kg	71		98		98		98							
Piping connections	Liquid pipe	Inch (mm)	3/8 (9,52)		3/8 (9,52)		3/8 (9,52)		3/8 (9,52)							
	Gas pipe	Inch (mm)	5/8 (15,88)		5/8 (15,88)		5/8 (15,88)		5/8 (15,88)							
Pipe length range		m	5 - 50		5 - 75		5 - 75		5 - 75							
Elevation difference (in/out) ⁷⁾		m	30		30		30		30							
Pipe length for additional gas		m	30		30		30		30							
Additional gas amount		g/m	50		50		50		50							
Refrigerant (R410A)		kg/TCO ₂ Eq.	2,35 / 4,9068		3,40 / 7,0992		3,40 / 7,0992		3,40 / 7,0992							
Operating range	Cool Min ~ Max	°C	-15 ~ +46		-15 ~ +46		-15 ~ +46		-15 ~ +46							
	Heat Min ~ Max	°C	-20 ~ +24		-20 ~ +24		-20 ~ +24		-20 ~ +24							

1) EER and COP calculation is based in accordance to EN14511. 2) For models below 12kW, the SCOP is calculated based on values of EU/626/2011. For models above 12kW, the SCOP is calculated based on values of EU/2281/2016. 3) The annual energy consumption is calculated in accordance to EU/626/2011. 4) Heating capacity is calculated including defrost factor correction. 5) Medium external static pressure setting from factory. 6) The sound pressure of the units shows the value measured at a position 1m in front of the main body and 1,5m from the ground. The sound pressure is measured in accordance with Eurovent 6/C/006-97 specification. 7) When installing the outdoor unit at a higher position than the indoor unit.* Recommended fuse for the indoor 3A.



SEER and SCOP: For KIT-71PF1E5D. INTERNET CONTROL: Optional. Compatible with all Panasonic connectivity solutions. For detailed information go to the Control Systems section.

Rating Conditions: Cooling Indoor 27°C DB / 19°C WB. Cooling Outdoor 35°C DB / 24°C WB. Heating Indoor 20°C DB. Heating Outdoor 7°C DB / 6°C WB. (DB: Dry Bulb; WB: Wet Bulb) Specifications subject to change without notice. For detailed information about ErP, please visit our websites www.aircon.panasonic.eu or www.gtc.panasonic.eu.

PACi STANDARD HIGH STATIC PRESSURE HIDE AWAY INVERTER+ • R410A GAS



The ducted systems are the ideal solution for flexible, concealed air conditioning and the optional 200mm spigots ensure simple, hassle-free connection to spiral ductwork.

High heating capacity at -7°C.

Technical focus

- Quiet operation from 26dB(A)
- Auto restart after power failure
- Auto changeover
- Twin split options
- DC FAN for better efficiency and control
- Built in drain pump
- Easy connection and control of external fan or ERV using the connector PAW-FDC on the indoor unit PCB. The external device can be control by the remote control of the Panasonic indoor unit

			Single Phase			
			6,0kW	7,1kW	10,0kW	12,5kW
KIT			KIT-60PFY1E5D	KIT-71PFY1E5D	KIT-100PFY1E5D	KIT-125PFY1E5D
Remote controller			CZ-RTC5B	CZ-RTC5B	CZ-RTC5B	CZ-RTC5B
Cooling capacity	Nominal (Min - Max)	kW	6,00 [2,00 - 7,10]	7,10 [2,00 - 7,70]	10,00 [2,70 - 11,50]	12,50 [3,80 - 13,50]
EER ¹⁾	Nominal (Min - Max)	W/W	3,35 [5,97 - 2,85]A	2,76 [5,97 - 2,48]D	3,01 [5,09 - 2,74]B	3,05 [4,22 - 2,70]B
SEER ²⁾		W/W	5,50A	5,40A	5,40A	5,11
P _{design}		kW	6,00	7,10	10,00	12,50
Input power cooling	Nominal (Min - Max)	kW	1,79 [0,34 - 2,49]	2,57 [0,34 - 3,10]	3,32 [0,53 - 4,20]	4,10 [0,90 - 5,00]
Annual energy consumption ³⁾		kWh/a	382	460	648	—
Heating capacity	Nominal (Min - Max)	kW	6,00 [1,80 - 7,00]	7,10 [1,80 - 8,10]	10,00 [2,10 - 13,80]	12,50 [3,40 - 15,00]
Heating capacity at -7°C / -15°C ⁴⁾		kW	— / —	— / —	— / —	11,00 / —
COP ¹⁾	Nominal (Min - Max)	W/W	4,38 [6,32 - 4,12]A	4,10 [6,32 - 3,68]A	3,80 [5,12 - 3,45]A	3,82 [4,66 - 3,41]A
SCOP ²⁾		W/W	4,00A+	4,00A+	3,80A	3,60
P _{design} at -10°C		kW	6,00	6,00	9,50	12,50
Input power heating	Nominal (Min - Max)	kW	1,37 [0,29 - 1,70]	1,73 [0,29 - 2,20]	2,63 [0,41 - 4,00]	3,27 [0,73 - 4,40]
Annual energy consumption ³⁾		kWh/a	2100	2100	3500	—
Indoor unit			S-60PF1E5B	S-71PF1E5B	S-100PF1E5B	S-125PF1E5B
External static pressure ⁵⁾	Nominal (Min - Max)	Pa	70 [10 - 150]	70 [10 - 150]	100 [10 - 150]	100 [10 - 150]
Air volume	Hi / Med / Lo	m ³ /min	21/19/15	21/19/15	32/26/21	34/29/23
Sound pressure ⁶⁾	Hi / Med / Lo	dB(A)	35/32/26	35/32/26	38/34/31	39/35/32
Dimension	H x W x D	mm	290 x 1000 x 700	290 x 1000 x 700	290 x 1400 x 700	290 x 1400 x 700
Net weight		kg	33	33	45	45
Outdoor unit			U-60PEY2E5	U-71PEY2E5	U-100PEY1E5	U-125PEY1E5
Power source		V	220/230/240	220/230/240	220/230/240	220/230/240
Recommended fuse		A	—	—	25	30
Connection indoor / outdoor		mm ²	—	—	4	6
Current	Cool	A	8,40/8,10/7,75	12,20/11,70/11,20	15,10/14,50/13,90	18,80/18,00/17,20
	Heat	A	6,30/6,05/5,80	8,15/7,80/7,45	11,80/11,20/10,70	14,60/14,00/13,40
Air volume	Cool / Heat	m ³ /min	38/41	44/41	76/67	80/73
Sound pressure	Cool / Heat (Hi)	dB(A)	46/48	49/49	54/54	56/56
Dimension	H x W x D	mm	619 x 799 x 299	619 x 799 x 299	996 x 940 x 340	996 x 940 x 340
Net weight		kg	40	40	73	85
Piping connections	Liquid pipe	Inch (mm)	3/8 (9,52)	3/8 (9,52)	3/8 (9,52)	3/8 (9,52)
	Gas pipe	Inch (mm)	5/8 (15,88)	5/8 (15,88)	5/8 (15,88)	5/8 (15,88)
Pipe length range		m	3 - 40	3 - 40	5 - 50	5 - 50
Elevation difference (in/out) ⁷⁾		m	30	30	30	30
Pipe length for additional gas		m	30	30	30	30
Additional gas amount		g/m	40	40	50	50
Refrigerant (R410A)		kg/TCO ₂ Eq.	1,95/4,0716	1,95/4,0716	2,60/5,4288	3,20/6,6816
Operating range	Cool Min ~ Max	°C	-10 ~ +43	-10 ~ +43	-10 ~ +43	-10 ~ +43
	Heat Min ~ Max	°C	-15 ~ +24	-15 ~ +24	-15 ~ +24	-15 ~ +24

Accessories

CZ-RTC5B	Wired remote controller with Econavi button and datanavi
CZ-RWSK2 + CZ-RWSC3	Wireless remote controller
CZ-RE2C2	Simplified remote controller
PAW-WTRAY	Tray for condenser water compatible with base ground support
PAW-GRDBSE20	Outdoor base ground support for noise and vibration absorption
PAW-GRDSTD40	Outdoor elevation platform 400 x 900 x 400mm

Accessories

CZ-56DAF2	Air Outlet Plenum S . .PF1E5B 36, 45 & 50
CZ-90DAF2	Air Outlet Plenum S . .PF1E5B 60 & 71
CZ-160DAF2	Air Outlet Plenum S . .PF1E5B 100, 125 & 140
CZ-DUMPA90MF2	Air Inlet Plenum S . .PF1E5B 60 & 71
CZ-DUMPA160MF2	Air Inlet Plenum S . .PF1E5B 100, 125 & 140

PACi Kits

R410A



Optional Controller. Wired remote controller CZ-RTCSB Compatible with Econavi
 Optional Controller. Wireless remote controller CZ-RWSK2 + CZ-RWSC3
 Optional Controller. Simplified remote controller CZ-REZC2
 Optional Economizer Sensor. CZ-CENSC1



Air Outlet Plenum (without regulation adaptor)

Diameters	Model
36, 45 & 50	CZ-56DAF2
60 & 71	CZ-90DAF2
100, 125 & 140	CZ-160DAF2

Air Inlet Plenum

Diameters	Model
60 & 71	CZ-DUMPA90MF2
100, 125 & 140	CZ-DUMPA160MF2

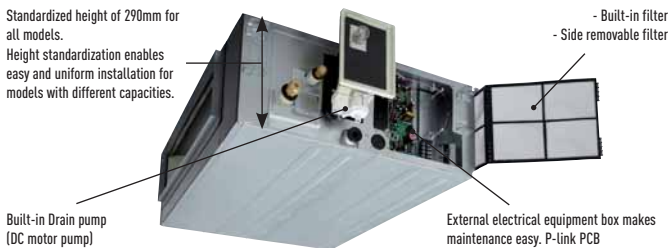

The static pressure outside the unit can be increased up to 150 Pa

Type	Pa	36	45	50	60	71	100	125	140
Standard	Pa	70	70	70	70	70	100	100	100
Maximum available setting	Pa	150	150	150	150	150	150	150	150

More powerful drain pump

Using a high-lift drain pump, drain piping can be elevated up to 785mm from the base of the unit.

KIT	Three Phase			
	10,0kW	12,5kW	14,0kW	
Remote controller	KIT-100PFY1E8D	KIT-125PFY1E8D	KIT-140PFY1E8D	
	CZ-RTCSB	CZ-RTCSB	CZ-RTCSB	
Cooling capacity	Nominal (Min - Max) kW	10,00 (2,70 - 11,50)	12,50 (3,80 - 13,50)	14,00 (3,30 - 15,50)
EER ¹⁾	Nominal (Min - Max) W/W	3,01 (5,09 - 2,74) B	3,05 (4,22 - 2,70) B	3,22 (3,93 - 2,58) A
SEER ²⁾	W/W	5,20 A	5,10	5,31
Pdesign	kW	10,00	12,50	14,00
Input power cooling	Nominal (Min - Max) kW	3,32 (0,53 - 4,20)	4,10 (0,90 - 5,00)	4,35 (0,84 - 6,00)
Annual energy consumption ³⁾	kWh/a	673	—	—
Heating capacity	Nominal (Min - Max) kW	10,00 (2,10 - 13,80)	12,50 (3,40 - 15,00)	14,00 (4,10 - 16,00)
Heating capacity at -7°C / -15°C ⁴⁾	kW	— / —	11,00 / —	12,32 / —
COP ¹⁾	Nominal (Min - Max) W/W	3,80 (5,12 - 3,45) A	3,82 (4,66 - 3,41) A	3,91 (4,56 - 3,08) A
SCOP ²⁾	W/W	3,80 A	3,60	3,53
Pdesign at -10°C	kW	9,50	12,50	14,00
Input power heating	Nominal (Min - Max) kW	2,63 (0,41 - 4,00)	3,27 (0,73 - 4,40)	3,58 (0,90 - 5,20)
Annual energy consumption ³⁾	kWh/a	3500	—	—
Indoor unit	S-100PF1E5B	S-125PF1E5B	S-140PF1E5B	
External static pressure ⁵⁾	Nominal (Min - Max) Pa	100 (10 - 150)	100 (10 - 150)	100 (10 - 150)
Air volume	Hi / Med / Lo m ³ /min	32/26/21	34/29/23	36/32/25
Sound pressure ⁶⁾	Hi / Med / Lo dB(A)	38/34/31	39/35/32	40/36/33
Dimension	HxWxD mm	290x1400x700	290x1400x700	290x1400x700
Net weight	kg	45	45	45
Outdoor unit	U-100PEY1E8	U-125PEY1E8	U-140PEY1E8	
Power source	V	380/400/415	380/400/415	380/400/415
Recommended fuse	A	16	16	16
Connection indoor / outdoor	mm ²	2,5	2,5	2,5
Current	Cool A	5,10/4,85/4,70	6,20/5,90/5,70	6,75/6,45/6,25
	Heat A	4,05/3,80/3,65	4,90/4,65/4,50	5,60/5,40/5,20
Air volume	Cool / Heat m ³ /min	76/67	80/73	135/120
Sound pressure	Cool / Heat (Hi) dB(A)	54/54	56/56	54/53
Dimension	HxWxD mm	996x940x340	996x940x340	1416x940x340
Net weight	kg	73	85	98
Piping connections	Liquid pipe Inch (mm)	3/8 (9,52)	3/8 (9,52)	3/8 (9,52)
	Gas pipe Inch (mm)	5/8 (15,88)	5/8 (15,88)	5/8 (15,88)
Pipe length range	m	5 - 50	5 - 50	5 - 50
Elevation difference (in/out) ⁷⁾	m	30	30	30
Pipe length for additional gas	m	30	30	30
Additional gas amount	g/m	50	50	50
Refrigerant (R410A)	kg/TCO ₂ Eq.	2,60/5,4288	3,20/6,6816	3,40/7,0992
Operating range	Cool Min ~ Max °C	-10 ~ +43	-10 ~ +43	-10 ~ +43
	Heat Min ~ Max °C	-15 ~ +24	-15 ~ +24	-15 ~ +24

1) EER and COP calculation is based in accordance to EN14511. 2) For models below 12kW, the SCOP is calculated based on values of EU/626/2011. For models above 12kW, the SCOP is calculated based on values of EU/2281/2016. 3) The annual energy consumption is calculated in accordance to EU/626/2011. 4) Heating capacity is calculated including defrost factor correction. 5) Medium external static pressure setting from factory. 6) The sound pressure of the units shows the value measured of a position 1m in front of the main body and 1,5m from the ground. The sound pressure is measured in accordance with Eurovent 6/C/006-97 specification. 7) When installing the outdoor unit at a higher position than the indoor unit.* Recommended fuse for the indoor 3A.



SEER and SCOP: KIT-60PFY1E5D. INTERNET CONTROL: Optional.
 Compatible with all Panasonic connectivity solutions. For detailed information go to the Control Systems section.

Rating Conditions: Cooling Indoor 27°C DB / 19°C WB. Cooling Outdoor 35°C DB / 24°C WB. Heating Indoor 20°C DB. Heating Outdoor 7°C DB / 6°C WB. (DB: Dry Bulb; WB: Wet Bulb)
 Specifications subject to change without notice. For detailed information about ErP, please visit our websites www.aircon.panasonic.eu or www.gtc.panasonic.eu.

PACi ELITE LOW STATIC PRESSURE HIDE AWAY INVERTER+ • R410A GAS



The depth of only 250mm provides greater installation flexibility and the unit can be used in more applications. Ideal for sites with narrow ceiling voids.

High heating capacity at -7°C.

Ultra-slim profile: 250mm height for all models.

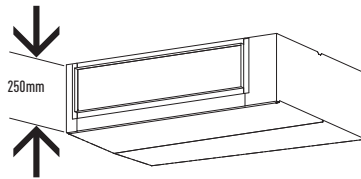

Technical focus

- Compact indoor units without loosing static pressure (Only 250mm high)
- 50 Pa static pressure
- Easy maintenance and service via external electrical box
- 3 speed centrifugal fan through wired or wireless remote control
- DC FAN for better efficiency and control
- Easy connection and control of external fan or ERV using the connector PAW-FDC on the indoor unit PCB. The external device can be control by the remote control of the Panasonic indoor unit

		Single Phase							
KIT			3,6kW	5,0kW	6,0kW	7,1kW	10,0kW	12,5kW	14,0kW
Remote controller			KIT-36PN1E5C CZ-RTC5B	KIT-50PN1E5C CZ-RTC5B	KIT-60PN1E5C CZ-RTC5B	KIT-71PN1E5C CZ-RTC5B	KIT-100PN1E5C CZ-RTC5B	KIT-125PN1E5C CZ-RTC5B	KIT-140PN1E5C CZ-RTC5B
Cooling capacity	Nominal (Min - Max)	kW	3,60(1,50 - 4,00)	5,00(1,50 - 5,60)	6,00(2,00 - 7,10)	7,10(2,50 - 8,00)	10,00(3,30 - 12,50)	12,50(3,30 - 14,00)	14,00(3,30 - 15,50)
EER ¹⁾	Nominal (Min - Max)	W/W	3,75(4,41 - 3,57)A	3,21(4,41 - 2,96)A	3,24(5,00 - 2,78)A	3,30(4,55 - 2,91)A	3,75(3,79 - 3,29)A	3,21(3,30 - 2,92)A	3,01(3,30 - 2,50)B
SEER ²⁾		W/W	4,60B	4,60B	5,50A	5,50A	6,00A+	5,44	5,27
Pdesign		kW	3,60	5,00	6,00	7,10	10,00	12,50	14,00
Input power cooling	Nominal (Min - Max)	kW	0,96(0,34 - 1,12)	1,56(0,34 - 1,89)	1,85(0,40 - 2,55)	2,15(0,55 - 2,75)	2,67(0,87 - 3,80)	3,89(1,00 - 4,80)	4,65(1,00 - 6,20)
Annual energy consumption ³⁾		kWh/a	274	380	382	452	583	—	—
Heating capacity	Nominal (Min - Max)	kW	4,00(1,50 - 5,00)	5,60(1,50 - 6,50)	7,00(1,80 - 8,00)	8,00(2,00 - 9,00)	11,20(4,10 - 14,00)	14,00(4,10 - 16,00)	16,00(4,10 - 18,00)
Heating capacity at -7°C / -15°C ⁴⁾		kW	— / —	— / —	— / —	7,52	12,04	13,48	14,24
COP ¹⁾	Nominal (Min - Max)	W/W	4,30(5,17 - 4,00)A	3,81(5,17 - 3,49)A	3,74(5,14 - 3,64)A	3,54(4,00 - 3,08)B	3,80(4,18 - 3,11)A	3,61(3,90 - 2,96)A	3,41(3,90 - 2,95)B
SCOP ²⁾		W/W	3,80A	3,80A	3,80A	3,70A	3,90A	3,66	3,58
Pdesign at -10°C		kW	3,60	3,80	5,60	6,50	10,00	12,50	14,00
Input power heating	Nominal (Min - Max)	kW	0,93(0,29 - 1,25)	1,47(0,29 - 1,86)	1,87(0,35 - 2,20)	2,26(0,50 - 2,92)	2,95(0,98 - 4,50)	3,88(1,05 - 5,40)	4,69(1,05 - 6,10)
Annual energy consumption ³⁾		kWh/a	1326	1478	2061	2458	3590	—	—
Indoor unit			S-36PN1E5A	S-50PN1E5A	S-60PN1E5A	S-71PN1E5A	S-100PN1E5A	S-125PN1E5A	S-140PN1E5A
External static pressure ⁵⁾	Nominal (Min - Max)	Pa	50(10 - 80)	50(10 - 80)	50(10 - 80)	50(10 - 80)	50(10 - 80)	50(10 - 80)	50(10 - 80)
Air volume	Cool / Heat	m ³ /min	14/12/10	16/13/11	22/20/16	22/20/16	36/33/26	38/35/28	40/37/30
Sound pressure ⁶⁾	Hi / Med / Lo	dB(A)	40/38/35	41/39/35	43/41/36	43/41/36	44/42/37	45/43/38	46/44/39
Dimension ⁷⁾	H x W x D	mm	250 x 780 x 650	250 x 780 x 650	250 x 1000 x 650	250 x 1000 x 650	250 x 1200 x 650	250 x 1200 x 650	250 x 1200 x 650
Net weight		kg	29	29	32	32	41	41	41
Outdoor unit			U-36PE2E5A	U-50PE2E5A	U-60PE2E5A	U-71PE1E5A	U-100PE1E5A	U-125PE1E5A	U-140PE1E5A
Power source		V	220/230/240	220/230/240	220/230/240	220/230/240	220/230/240	220/230/240	220/230/240
Recommended fuse		A	—	—	—	20	25	30	16
Connection indoor / outdoor		mm ²	—	—	—	2,5	4	6	2,5
Current	Cool	A	4,35/4,15/3,95	7,00/6,65/6,35	8,60/8,30/7,90	9,70/9,40/9,20	11,60/11,20/10,90	17,40/16,90/16,40	20,50/20,10/19,50
	Heat	A	4,10/4,00/3,80	6,60/6,30/6,05	8,75/8,35/8,00	10,20/9,90/9,70	12,80/12,50/12,20	17,30/16,80/16,30	20,60/20,20/19,60
Air volume	Cool / Heat	m ³ /min	38/38	38/41	38/41	60/60	110/95	130/110	135/120
Sound pressure	Cool / Heat (Hi)	dB(A)	45/46	46/48	46/49	48/50	52/52	53/53	54/55
Dimension	H x W x D	mm	619 x 799 x 299	619 x 799 x 299	619 x 799 x 299	996 x 940 x 340	1416 x 940 x 340	1416 x 940 x 340	1416 x 940 x 340
Net weight		kg	39	39	40	69	98	98	98
Piping connections	Liquid pipe	Inch (mm)	1/4(6,35)	1/4(6,35)	3/8(9,52)	3/8(9,52)	3/8(9,52)	3/8(9,52)	3/8(9,52)
	Gas pipe	Inch (mm)	1/2(12,70)	1/2(12,70)	5/8(15,88)	5/8(15,88)	5/8(15,88)	5/8(15,88)	5/8(15,88)
Pipe length range		m	3 - 40	3 - 40	3 - 40	5 - 50	5 - 75	5 - 75	5 - 75
Elevation difference (in/out) ⁸⁾		m	30	30	30	30	30	30	30
Pipe length for additional gas		m	30	30	30	30	30	30	30
Additional gas amount		g/m	20	20	40	50	50	50	50
Refrigerant (R410A)		kg/TCO ₂ Eq.	1,40/2,9232	1,40/2,9232	1,95/4,0716	2,35/4,9068	3,40/7,0992	3,40/7,0992	3,40/7,0992
Operating range	Cool Min ~ Max	°C	-15 ~ +46	-15 ~ +46	-15 ~ +46	-15 ~ +46	-15 ~ +46	-15 ~ +46	-15 ~ +46
	Heat Min ~ Max	°C	-20 ~ +24	-20 ~ +24	-20 ~ +24	-20 ~ +24	-20 ~ +24	-20 ~ +24	-20 ~ +24

Accessories	
CZ-RTC5B	Wired remote controller with Econavi button and datanavi
CZ-RWSK2 + CZ-RWSC3	Wireless remote controller
CZ-RE2C2	Simplified remote controller
PAW-WTRAY	Tray for condenser water compatible with base ground support
PAW-GRDBSE20	Outdoor base ground support for noise and vibration absorption
PAW-GRDSTD40	Outdoor elevation platform 400 x 900 x 400mm

Accessories	
PAW-WPH7	Wind protection shield for 5kW outdoor unit
PAW-WPH9	Wind protection shield for outdoor units 6/7kW Elite and 10/12,5kW Standard
PAW-WPH10	Wind protection shield for outdoor units from 10 to 14kW Elite and 14kW Standard

PACi Kits

R410A



Optional Controller. Wired remote controller CZ-RTCSB Compatible with Econavi
 Optional Controller. Wireless remote controller CZ-RWSC2 + CZ-RWSC3
 Optional Controller. Simplified remote controller CZ-REZC2
 Optional Econavi Sensor. CZ-CENSC1



System Example

An inspection port (450mmx450mm or more) is required at the control-box side of the indoor unit body.

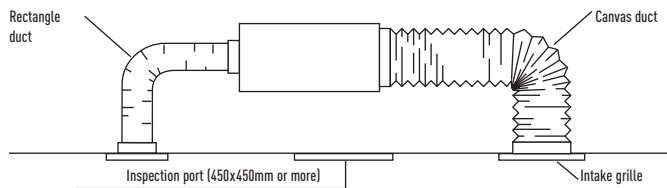

Cold Drafts Reduction at Heating

Accurate DX Coil temperature measurement by E1 and E2 sensor to reduce cold drafts at heating and increasing efficiency and comfort.

Before spec-in, please consult with an authorized Panasonic dealer.

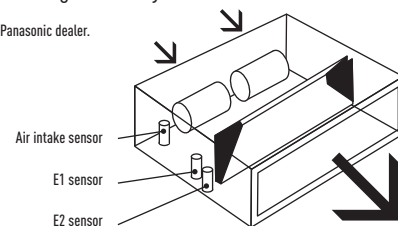

			Three Phase			
			7,1kW	10,0kW	12,5kW	14,0kW
KIT			KIT-71PN1E8C	KIT-100PN1E8C	KIT-125PN1E8C	KIT-140PN1E8C
Remote controller			CZ-RTCSB	CZ-RTCSB	CZ-RTCSB	CZ-RTCSB
Cooling capacity	Nominal (Min - Max)	kW	7,10 (2,50 - 8,00)	10,00 (3,30 - 12,50)	12,50 (3,30 - 14,00)	14,00 (3,30 - 15,50)
EER ¹⁾	Nominal (Min - Max)	W/W	3,30 (3,79 - 2,91) A	3,75 (3,79 - 3,29) A	3,21 (3,30 - 2,92) A	3,01 (3,30 - 2,50) A
SEER ²⁾		W/W	5,10 A	5,60 A+	5,44	5,27
Pdesign		kW	7,10	10,00	12,50	14,00
Input power cooling	Nominal (Min - Max)	kW	2,15 (0,66 - 2,75)	2,67 (0,87 - 3,80)	3,89 (1,00 - 4,80)	4,65 (1,00 - 6,20)
Annual energy consumption ³⁾		kWh/a	487	621	—	—
Heating capacity	Nominal (Min - Max)	kW	8,00 (2,00 - 9,00)	11,20 (4,10 - 14,00)	14,00 (4,10 - 16,00)	16,00 (4,10 - 18,00)
Heating capacity at -7°C / -15°C ⁴⁾		kW	7,52	12,04	13,48	14,24
COP ¹⁾	Nominal (Min - Max)	W/W	3,54 (3,33 - 3,00) B	3,80 (4,18 - 3,11) A	3,61 (3,90 - 2,96) A	3,41 (3,90 - 2,95) B
SCOP ²⁾		W/W	3,80 A	3,80 A	3,66	3,58
Pdesign at -10°C		kW	6,20	10,00	12,50	14,00
Input power heating	Nominal (Min - Max)	kW	2,26 (0,60 - 3,00)	2,95 (0,98 - 4,50)	3,88 (1,05 - 5,40)	4,69 (1,05 - 6,10)
Annual energy consumption ³⁾		kWh/a	2284	3684	—	—
Indoor unit			S-71PN1E5A	S-100PN1E5A	S-125PN1E5A	S-140PN1E5A
External static pressure ⁵⁾	Nominal (Min - Max)	Pa	50 (10 - 80)	50 (10 - 80)	50 (10 - 80)	50 (10 - 80)
Air volume	Cool / Heat	m ³ /min	22 / 20 / 16	36 / 33 / 26	38 / 35 / 28	40 / 37 / 30
Sound pressure ⁶⁾	Hi / Med / Lo	dB(A)	43 / 41 / 36	44 / 42 / 37	45 / 43 / 38	46 / 44 / 39
Dimension ⁷⁾	H x W x D	mm	250 x 1000 x 650	250 x 1200 x 650	250 x 1200 x 650	250 x 1200 x 650
Net weight		kg	32	41	41	41
Outdoor unit			U-71PE1E8A	U-100PE1E8A	U-125PE1E8A	U-140PE1E8A
Power source		V	380 / 400 / 415	380 / 400 / 415	380 / 400 / 415	380 / 400 / 415
Recommended fuse		A	16	16	16	16
Connection indoor / outdoor		mm ²	2,5	2,5	2,5	2,5
Current	Cool	A	3,25 / 3,10 / 3,00	3,95 / 3,75 / 3,60	5,80 / 5,50 / 5,30	6,95 / 6,60 / 6,35
	Heat	A	3,35 / 3,20 / 3,10	4,35 / 4,15 / 4,00	5,80 / 5,50 / 5,30	7,00 / 6,65 / 6,45
Air volume	Cool / Heat	m ³ /min	60 / 60	110 / 95	130 / 110	135 / 120
Sound pressure	Cool / Heat (Hi)	dB(A)	48 / 50	52 / 52	53 / 53	54 / 55
Dimension	H x W x D	mm	996 x 940 x 340	1416 x 940 x 340	1416 x 940 x 340	1416 x 940 x 340
Net weight		kg	71	98	98	98
Piping connections	Liquid pipe	Inch (mm)	3/8 (9,52)	3/8 (9,52)	3/8 (9,52)	3/8 (9,52)
	Gas pipe	Inch (mm)	5/8 (15,88)	5/8 (15,88)	5/8 (15,88)	5/8 (15,88)
Pipe length range		m	5 - 50	5 - 75	5 - 75	5 - 75
Elevation difference (in/out) ⁸⁾		m	30	30	30	30
Pipe length for additional gas		m	30	30	30	30
Additional gas amount		g/m	50	50	50	50
Refrigerant (R410A)		kg/TCO ₂ Eq.	2,35 / 4,9068	3,40 / 7,0992	3,40 / 7,0992	3,40 / 7,0992
Operating range	Cool Min ~ Max	°C	-15 ~ +46	-15 ~ +46	-15 ~ +46	-15 ~ +46
	Heat Min ~ Max	°C	-20 ~ +24	-20 ~ +24	-20 ~ +24	-20 ~ +24

1) EER and COP calculation is based in accordance to EN14511. 2) For models below 12kW, the SCOP is calculated based on values of EU/626/2011. For models above 12kW, the SCOP is calculated based on values of EU/2281/2016. 3) The annual energy consumption is calculated in accordance to EU/626/2011. 4) Heating capacity is calculated including defrost factor correction. 5) Medium external static pressure setting from factory. 6) The sound pressure of the units shows the value measured of a position 1m in front of the main body and 1,5m from the ground. The sound pressure is measured in accordance with Eurovent 6/C/006-97 specification. 7) Add 100mm for piping port. 8) When installing the outdoor unit at a higher position than the indoor unit.* Recommended fuse for the indoor 3A.



SEER and SCOP: KIT-100PN1E8C. INTERNET CONTROL: Optional.
 Compatible with all Panasonic connectivity solutions. For detailed information go to the Control Systems section.

Rating Conditions: Cooling Indoor 27°C DB / 19°C WB. Cooling Outdoor 35°C DB / 24°C WB. Heating Indoor 20°C DB. Heating Outdoor 7°C DB / 6°C WB. (DB: Dry Bulb; WB: Wet Bulb)
 Specifications subject to change without notice. For detailed information about ErP, please visit our websites www.aircon.panasonic.eu or www.ptc.panasonic.eu.

PACi STANDARD LOW STATIC PRESSURE HIDE AWAY INVERTER+ • R410A GAS



The depth of only 250mm provides greater installation flexibility and the unit can be used in more applications. Ideal for sites with narrow ceiling voids.

High heating capacity at -7°C.

Ultra-slim profile: 250mm height for all models.

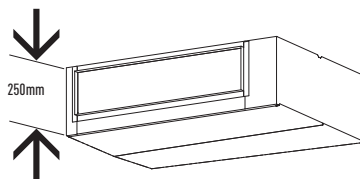

Technical focus

- Compact indoor units without losing static pressure (Only 250mm high)
- 50 Pa static pressure
- Easy maintenance and service via external electrical box
- 3 speed centrifugal fan through wired or wireless remote control
- DC FAN for better efficiency and control
- Easy connection and control of external fan or ERV using the connector PAW-FDC on the indoor unit PCB. The external device can be control by the remote control of the Panasonic indoor unit

		Single Phase				
KIT		6,0kW	7,1kW	10,0kW	12,5kW	
Remote controller		KIT-60PNY1E5C CZ-RTC5B	KIT-71PNY1E5C CZ-RTC5B	KIT-100PNY1E5C CZ-RTC5B	KIT-125PNY1E5C CZ-RTC5B	
Cooling capacity	Nominal (Min - Max)	kW	6,00 [2,00 - 7,10]	7,10 [2,00 - 7,70]	10,00 [2,70 - 11,50]	12,50 [3,80 - 13,50]
EER ¹⁾	Nominal (Min - Max)	W/W	3,21 [5,00 - 2,78] A	2,76 [5,00 - 2,48] D	2,81 [4,74 - 2,67] C	2,81 [4,00 - 2,60] C
SEER ²⁾		W/W	4,80 B	5,10 A	5,30 A	4,95
P _{design}		kW	6,00	7,10	10,00	12,50
Input power cooling	Nominal (Min - Max)	kW	1,87 [0,40 - 2,55]	2,57 [0,40 - 3,10]	3,56 [0,57 - 4,30]	4,45 [0,95 - 5,20]
Annual energy consumption ³⁾		kWh/a	437	487	660	—
Heating capacity	Nominal (Min - Max)	kW	6,00 [1,80 - 7,00]	7,10 [1,80 - 8,10]	10,00 [2,10 - 13,80]	12,50 [3,40 - 15,00]
Heating capacity at -7°C / -15°C ⁴⁾		kW	— / —	— / —	9,97	10,97
COP ¹⁾	Nominal (Min - Max)	W/W	3,73 [5,14 - 3,78] A	3,70 [5,14 - 3,31] A	3,41 [4,67 - 3,37] B	3,41 [4,36 - 3,26] B
SCOP ²⁾		W/W	3,80 A	3,80 A	3,80 A	3,52
P _{design} at -10°C		kW	5,60	5,60	7,60	12,50
Input power heating	Nominal (Min - Max)	kW	1,61 [0,35 - 1,85]	1,92 [0,35 - 2,45]	2,94 [0,45 - 4,10]	3,67 [0,78 - 4,60]
Annual energy consumption ³⁾		kWh/a	2061	2061	2800	—
Indoor unit			S-60PN1E5A	S-71PN1E5A	S-100PN1E5A	S-125PN1E5A
External static pressure ⁵⁾	Nominal (Min - Max)	Pa	50 [10 - 80]	50 [10 - 80]	50 [10 - 80]	50 [10 - 80]
Air volume	Cool / Heat	m ³ /min	22/20/16	22/20/16	36/33/26	38/35/28
Sound pressure ⁶⁾	Hi / Med / Lo	dB(A)	43/41/36	43/41/36	44/42/37	45/43/38
Dimension ⁷⁾	H x W x D	mm	250 x 1000 x 650	250 x 1000 x 650	250 x 1200 x 650	250 x 1200 x 650
Net weight		kg	32	32	41	41
Outdoor unit			U-60PEY2E5	U-71PEY2E5	U-100PEY1E5	U-125PEY1E5
Power source		V	220/230/240	220/230/240	220/230/240	220/230/240
Recommended fuse		A	—	—	25	30
Connection indoor / outdoor		mm ²	—	—	4	6
Current	Cool	A	8,70/8,40/8,00	12,10/11,60/11,20	16,00/15,30/14,80	20,10/19,30/18,70
	Heat	A	7,40/7,10/6,80	9,00/8,60/8,25	13,00/12,50/12,10	16,50/15,80/15,20
Air volume	Cool / Heat	m ³ /min	38/41	44/41	110/95	80/73
Sound pressure	Cool / Heat (Hi)	dB(A)	46/48	49/49	52/52	56/56
Dimension	H x W x D	mm	619 x 799 x 299	619 x 799 x 299	996 x 940 x 340	996 x 940 x 340
Net weight		kg	40	40	73	85
Piping connections	Liquid pipe	Inch (mm)	3/8 (9,52)	3/8 (9,52)	3/8 (9,52)	3/8 (9,52)
	Gas pipe	Inch (mm)	5/8 (15,88)	5/8 (15,88)	5/8 (15,88)	5/8 (15,88)
Pipe length range		m	3 - 40	3 - 40	5 - 50	5 - 50
Elevation difference (in/out) ⁸⁾		m	30	30	30	30
Pipe length for additional gas		m	30	30	30	30
Additional gas amount		g/m	40	40	50	50
Refrigerant (R410A)		kg/TCO ₂ Eq.	1,95/4,0716	1,95/4,0716	2,60/5,4288	3,20/6,6816
Operating range	Cool Min ~ Max	°C	-10 ~ +43	-10 ~ +43	-10 ~ +43	-10 ~ +43
	Heat Min ~ Max	°C	-15 ~ +24	-15 ~ +24	-15 ~ +24	-15 ~ +24

Accessories

CZ-RTC5B	Wired remote controller with Econavi button and datanavi
CZ-RWSK2 + CZ-RWSC3	Wireless remote controller
CZ-RE2C2	Simplified remote controller
PAW-WTRAY	Tray for condenser water compatible with base ground support
PAW-GRDBSE20	Outdoor base ground support for noise and vibration absorption
PAW-GRDSTD40	Outdoor elevation platform 400 x 900 x 400mm

Accessories

PAW-WPH7	Wind protection shield for 5kW outdoor unit
PAW-WPH9	Wind protection shield for outdoor units 6/7kW Elite and 10/12,5kW Standard
PAW-WPH10	Wind protection shield for outdoor units from 10 to 14kW Elite and 14kW Standard

PACi Kits

R410A



System Example

An inspection port (450mmx450mm or more) is required at the control-box side of the indoor unit body.

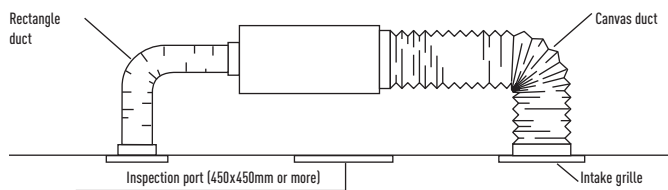

Cold Drafts Reduction at Heating

Accurate DX Coil temperature measurement by E1 and E2 sensor to reduce cold drafts at heating and increasing efficiency and comfort.

Before spec-in, please consult with an authorized Panasonic dealer.

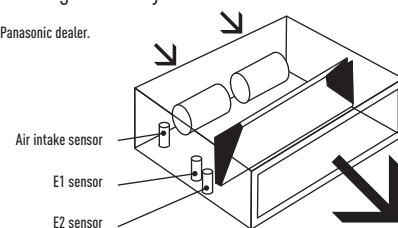

KIT	Three Phase			
	10,0kW	12,5kW	14,0kW	
Remote controller	KIT-100PNY1E8C	KIT-125PNY1E8C	KIT-140PNY1E8C	
	CZ-RTCSB	CZ-RTCSB	CZ-RTCSB	
Cooling capacity	Nominal (Min - Max) kW	10,00 [2,70 - 11,50]	12,50 [3,80 - 13,50]	14,00 [3,30 - 15,50]
EER ¹⁾	Nominal (Min - Max) W/W	2,81 [4,74 - 2,67] C	2,81 [4,00 - 2,60] C	2,98 [3,93 - 2,58] C
SEER ²⁾	W/W	5,20 A	4,95	5,18
Pdesign	kW	10,00	12,50	14,00
Input power cooling	Nominal (Min - Max) kW	3,56 [0,57 - 4,30]	4,45 [0,95 - 5,20]	4,70 [0,84 - 6,00]
Annual energy consumption ³⁾	kWh/a	673	—	—
Heating capacity	Nominal (Min - Max) kW	10,00 [2,10 - 13,80]	12,50 [3,40 - 15,00]	14,00 [4,10 - 16,00]
Heating capacity at -7°C / -15°C ⁴⁾	kW	9,97	10,97	13,35
COP ¹⁾	Nominal (Min - Max) W/W	3,41 [4,67 - 3,37] B	3,41 [4,36 - 3,26] B	3,52 [4,56 - 3,08] B
SCOP ²⁾	W/W	3,80 A	3,52	3,52
Pdesign at -10°C	kW	7,60	12,50	14,00
Input power heating	Nominal (Min - Max) kW	2,94 [0,45 - 4,10]	3,67 [0,78 - 4,60]	3,88 [1,05 - 5,40]
Annual energy consumption ³⁾	kWh/a	2800	—	—
Indoor unit	S-100PN1E5A	S-125PN1E5A	S-140PN1E5A	
External static pressure ⁵⁾	Nominal (Min - Max) Pa	50 [10 - 80]	50 [10 - 80]	50 [10 - 80]
Air volume	Cool / Heat m ³ /min	36/33/26	38/35/28	40/37/30
Sound pressure ⁶⁾	Hi / Med / Lo dB(A)	44/42/37	45/43/38	46/44/39
Dimension ⁷⁾	HxWxD mm	250x1200x650	250x1200x650	250x1200x650
Net weight	kg	41	41	41
Outdoor unit	U-100PEY1E8	U-125PEY1E8	U-140PEY1E8	
Power source	V	380/400/415	380/400/415	380/400/415
Recommended fuse	A	16	16	16
Connection indoor / outdoor	mm ²	2,5	2,5	2,5
Current	Cool A	5,45/5,20/5,05	6,85/6,50/6,25	7,05/6,50/6,45
	Heat A	4,45/4,25/4,10	5,55/5,30/5,10	5,90/5,60/5,40
Air volume	Cool / Heat m ³ /min	76/67	80/73	135/120
Sound pressure	Cool / Heat (Hi) dB(A)	54/54	56/56	54/53
Dimension	HxWxD mm	996x940x340	996x940x340	1416x940x340
Net weight	kg	73	85	98
Piping connections	Liquid pipe Inch (mm)	3/8 [9,52]	3/8 [9,52]	3/8 [9,52]
	Gas pipe Inch (mm)	5/8 [15,88]	5/8 [15,88]	5/8 [15,88]
Pipe length range	m	5 - 50	5 - 50	5 - 50
Elevation difference (in/out) ⁸⁾	m	30	30	30
Pipe length for additional gas	m	30	30	30
Additional gas amount	g/m	50	50	50
Refrigerant (R410A)	kg/TCO: Eq.	2,60/5,4288	3,20/6,6816	3,40/7,0992
Operating range	Cool Min ~ Max °C	-10 ~ +43	-10 ~ +43	-10 ~ +43
	Heat Min ~ Max °C	-15 ~ +24	-15 ~ +24	-15 ~ +24

1) EER and COP calculation is based in accordance to EN14511. 2) For models below 12kW, the SCOP is calculated based on values of EU/626/2011. For models above 12kW, the SCOP is calculated based on values of EU/2281/2016. 3) The annual energy consumption is calculated in accordance to EU/626/2011. 4) Heating capacity is calculated including defrost factor correction. 5) Medium external static pressure setting from factory. 6) The sound pressure of the units shows the value measured of a position 1m in front of the main body and 1,5m from the ground. The sound pressure is measured in accordance with Eurovent 6/C/006-97 specification. 7) Add 100mm for piping port. 8) When installing the outdoor unit at a higher position than the indoor unit.* Recommended fuse for the indoor 3A.



SEER and SCOP: KIT-100PNY1E5C. INTERNET CONTROL: Optional.
Compatible with all Panasonic connectivity solutions. For detailed information go to the Control Systems section.

Rating Conditions: Cooling Indoor 27°C DB / 19°C WB. Cooling Outdoor 35°C DB / 24°C WB. Heating Indoor 20°C DB. Heating Outdoor 7°C DB / 6°C WB. (DB: Dry Bulb; WB: Wet Bulb)
Specifications subject to change without notice. For detailed information about ErP, please visit our websites www.aircon.panasonic.eu or www.ptc.panasonic.eu.

**BIG PACi HIGH STATIC PRESSURE HIDE AWAY
20,0-25,0kW INVERTER+ • R410A GAS**



Panasonic breaks new ground in offering high performance and power in a small space

- High efficiency: Panasonic compressor
- Better partial load
- More flexible
- Bluefin anti-rust coating
- 0-10V control demand

The light net weight and compact design enables easier installation in any commercial space. The twin fan system saves valuable footprint compared to traditional 20,0-25,0kW systems which are larger and therefore require more space.

All "A" Functions

- Control demand 0-10V via CZ-CAPBC2
- Schedule peak cut
- Advanced energy saving functionalities available in Elite series
- Compact design: Good size to install balcony
- Suitable for mid, small project: piping design is suitable for light commercial and residential project

The 20,0-25,0kW from Panasonic is ideally suited for large retail applications and other large areas not needing the higher capacities of VRF systems.

Enlarged heat exchanger surface area with double surface

The heat exchanger features a double-surface construction. Compared to the divided dual-surface construction in current models, there is no division of space and the area for heat exchange is larger. Also, highly efficient piping pattern increases heat exchange performance by 5%.

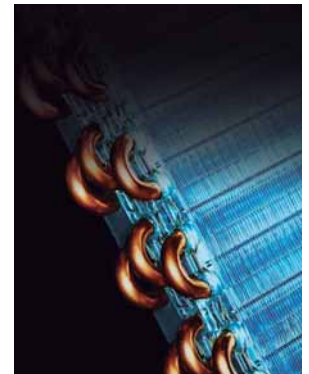

Bluefin

An air conditioner's performance depends largely on its condenser, which can take a beating from exposure to salty air, wind, dust and other corrosive factors. Panasonic has found a way to expand the life of our condensers, using a layer of our original anti-rust coating. This special coating lets you enjoy more years of reliable comfort plus extra economy over the long run.

Panasonic Compressor

Best inverter control providing better partial load in industry* 10%-100% Frequency Hz. Wider operation Hz range of compressor realize more high efficient operation through the year.

* Compared current model is the unit for European market.

PACi Kits

R410A



Optional Controller.
Wired remote controller
CZ-RTC5B
Compatible with Econavi



Optional Controller
Wireless remote controller
CZ-RWSK2 + CZ-RWSC3



Optional Controller.
Simplified remote controller
CZ-RE2C2



Optional Econavi Sensor.
CZ-CENSC1



Panasonic breaks new ground in offering high performance and power in a small space

The 8-10HP from Panasonic is ideally suited for large retail applications and other large areas not needing the higher capacities of VRF systems. The lightweight and compact design enables easier installation in any commercial space. The twin fan system saves valuable footprint compared to traditional 8-10HP systems which are larger and therefore require more space.

High heating capacity at -7°C.

Technical focus

- High efficiency:
- Panasonic compressor
- Better partial load
- More flexible
- Bluefin anti-rust coating
- 0-10V control demand

			Three Phase	
			20,0kW	25,0kW
KIT			KIT-200PE2E5D	KIT-250PE2E5D
Remote controller			CZ-RTC5B	CZ-RTC5B
Cooling capacity	Nominal (Min - Max)	kW	19,50 (5,40 - 22,40)	25,00 (6,30 - 28,00)
EER ¹⁾		W/W	3,11 B	2,91 C
SEER ²⁾		W/W	5,34	4,83
Pdesign		kW	19,50	25,00
Input power cooling		kW	5,97	8,04
Heating capacity	Nominal (Min - Max)	kW	22,40 (5,60 - 25,00)	28,00 (7,10 - 31,50)
Heating capacity at -7°C / -15°C ³⁾		kW	20,00 / 17,00	25,20 / 21,42
COP ¹⁾		W/W	3,54 B	3,64 A
SCOP ²⁾		W/W	3,55	3,56
Pdesign at -10°C		kW	17,00	20,00
Input power heating		kW	6,02	7,14
Indoor unit			S-200PE2E5	S-250PE2E5
Power source		V / ph / Hz	220 - 230 - 240 / 1 / 50	220 - 230 - 240 / 1 / 50
External static pressure at shipment (with booster cable) ⁴⁾		Pa	60 - 140 - 270	72 - 140 - 270
Air volume	Hi / Med / Lo	m ³ /min	56 / 51 / 44	72 / 63 / 53
Sound pressure ⁵⁾	Hi / Med / Lo	dB(A)	43 / 41 / 38	47 / 45 / 42
Dimension	H x W x D	mm	479 x 1453 x 1205	479 x 1453 x 1205
Net weight		kg	100	104
Outdoor unit			U-200PE2E8A	U-250PE2E8A
Power source		V / ph / Hz	380 - 400 - 415 / 3 / 50	380 - 400 - 415 / 3 / 50
Recommended fuse		A	15	20
Air volume	Cool / Heat	m ³ /min	164	160
Sound pressure ⁵⁾	Cool / Heat (Hi)	dB(A)	60 / 62	61 / 63
Dimension ⁶⁾	H x W x D	mm	1500 x 980 x 370	1500 x 980 x 370
Net weight		kg	127	138
Piping connections	Liquid pipe	Inch (mm)	3/8 (9,52)	1/2 (12,70)
	Gas pipe	Inch (mm)	1 (25,40)	1 (25,40)
Pipe length range		m	5 - 120	5 - 120
Elevation difference (in/out) ⁷⁾		m	30	30
Pipe length for additional gas		m	30	30
Additional gas amount		g/m	50	80
Refrigerant (R410A)		kg/TCO: Eq.	5,60 / 11,6928	6,40 / 13,3632
Operating range	Cool Min ~ Max	°C	-15 ~ +46	-15 ~ +46
	Heat Min ~ Max	°C	-20 ~ +24	-20 ~ +24

Accessories	
CZ-RTC5B	Wired remote controller with Econavi button and datanavi
CZ-RWSK2 + CZ-RWSC3	Wireless remote controller
CZ-RE2C2	Simplified remote controller
PAW-GRDSTD40	Outdoor elevation platform 400 x 900 x 400mm
PAW-WPH8	Wind protection shield for U-200PE2E8A and U-250PE2E8A

Accessories	
CZ-TREMIESPW706	Air Outlet Plenum (suitable for rigid + flexible duct) for S-250PE2E5
CZ-TREMIESPW705	Air Outlet Plenum (suitable for rigid + flexible duct) for S-200PE2E5

1) EER and COP calculation is based in accordance to EN14511. 2) For models below 12kW, the SCOP is calculated based on values of EU/626/2011. For models above 12kW, the SCOP is calculated based on values of EU/2281/2016. 3) Heating capacity is calculated including defrost factor correction. 4) Medium external static pressure setting from factory. 5) The sound pressure of the units shows the value measured at a position 1m in front of the main body and 1,5m from the ground. The sound pressure is measured in accordance with Eurovent 6/C/006-97 specification. 6) Add 100mm for indoor unit or 70mm for outdoor unit for piping port. 7) When installing the outdoor unit at a higher position than the indoor unit. * No filter included.



INTERNET CONTROL: Optional.
Compatible with all Panasonic connectivity solutions. For detailed information go to the Control Systems section.

Rating Conditions: Cooling Indoor 27°C DB / 19°C WB. Cooling Outdoor 35°C DB / 24°C WB. Heating Indoor 20°C DB. Heating Outdoor 7°C DB / 6°C WB. (DB: Dry Bulb; WB: Wet Bulb)
Specifications subject to change without notice. For detailed information about ErP, please visit our websites www.aircon.panasonic.eu or www.gtc.panasonic.eu.

PACi SINGLE, TWIN, TRIPLE AND DOUBLE-TWIN SYSTEM • R32 GAS AND • R410A GAS

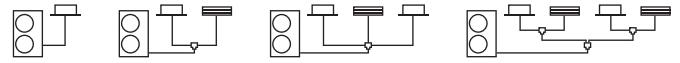

1 PACi Standard from 10,0 to 12,5kW

Up to 2 indoor units connectable on the same outdoor. Panasonic's PACi units can be installed as single and twin systems. The indoor units can be combined following the selection table. The operation will always be simultaneous. All the indoor units will work with the same settings.

2 PACi Elite from 7,1 to 14,0kW

Up to 4 indoor units can be connected to the same outdoor unit. Panasonic's PACi units 71, 100, 125 and 140 can be installed as twin, triple and double-twin systems. The indoor units can be combined as per the selection table. The operation will always be simultaneous. All the indoor units will work with the same settings.

3 Big PACi Elite from 20,0 to 25,0kW

Up to 4 indoor units can be connected to the same outdoor unit. Panasonic's PACi units 200 and 250 can be installed as twin, triple and double-twin systems. The indoor units can be combined as per the selection table. The operation will always be simultaneous. All the indoor units will work with the same settings.

With this system, a single outdoor unit can split capacity for up to 4 indoor areas simultaneously. This makes the system particularly apt for common areas. It reduces noise concentration and enables the same temperature to be reached around the room. A mix of indoor units can be installed (wall, cassette, duct, ceiling) in one system.

Indoor units

	NEW Wall	4 Way 90x90 Cassette	4 Way 60x60 Cassette	Ceiling	High Static Pressure Hide Away	Low Static Pressure Hide Away
3,6kW	S-36PK2E5B	S-36PU2E5B	S-36PY2E5A	S-36PT2E5B	S-36PF1E5B	S-36PN1E5A
4,5kW	S-45PK2E5B	S-45PU2E5B	S-45PY2E5A	S-45PT2E5B	S-45PF1E5B	S-45PN1E5A
5,0kW	S-50PK2E5B	S-50PU2E5B	S-50PY2E5A	S-50PT2E5B	S-50PF1E5B	S-50PN1E5A
6,0kW	S-60PK2E5B	S-60PU2E5B		S-60PT2E5B	S-60PF1E5B	S-60PN1E5A
7,1kW	S-71PK2E5B	S-71PU2E5B		S-71PT2E5B	S-71PF1E5B	S-71PN1E5A
10,0kW	S-100PK2E5B	S-100PU2E5B		S-100PT2E5B	S-100PF1E5B	S-100PN1E5A
12,5kW		S-125PU2E5B		S-125PT2E5B	S-125PF1E5B	S-125PN1E5A
14,0kW		S-140PU2E5B		S-140PT2E5B	S-140PF1E5B	S-140PN1E5A

Outdoor units

	NEW PACi Standard Single and Twin System • R32 GAS	PACi Standard Single and Twin System • R410A GAS	PACi Elite Twin, Triple and Double-Twin System from 7,1 to 14,0kW • R410A GAS	PACi Elite Twin, Triple and Double-Twin System from 20,0 to 25,0kW • R410A GAS
7,1kW		U-71PEY2E5	U-71PE1E5A // U-71PE1E8A	
10,0kW	U-100PZ2E5 // U-100PZ2E8	U-100PEY1E5 // U-100PEY1E8	U-100PE1E5A // U-100PE1E8A	
12,5kW	U-125PZ2E5 // U-125PZ2E8	U-125PEY1E5 // U-125PEY1E8	U-125PE1E5A // U-125PE1E8A	
14,0kW	U-140PZ2E5 // U-140PZ2E8	U-140PEY1E8	U-140PE1E5A // U-140PE1E8A	
20,0kW				U-200PE2E8A
25,0kW				U-250PE2E8A

PACi Standard Single/Simultaneous operation system combinations • R32 GAS and • R410A GAS

Indoor	7,1kW	10,0kW	12,5kW	14,0kW
3,6kW				
5,0kW		Twin U-100 S-50 S-50		
6,0kW			Twin U-125 S-60 S-60	
7,1kW	Single ¹ U-71 S-71			Twin U-140 S-71 S-71
10,0kW		Single ¹ U-100 S-100		
12,5kW			Single ¹ U-125 S-125	
14,0kW				Single ¹ U-140 S-140

PACi Elite from 7,1 to 14,0kW Single/Simultaneous operation system combinations • R410A GAS

Indoor	7,1kW	10,0kW	12,5kW	14,0kW
3,6kW	Twin U-71 S-36 S-36	Triple U-100 S-36 S-36 S-36	Double-Twin U-125 S-36 S-36 S-36 S-36	
4,5kW			Triple U-125 S-45 S-45 S-45	
5,0kW		Twin U-100 S-50 S-50		Triple U-140 S-50 S-50 S-50
6,0kW			Twin U-125 S-60 S-60	
7,1kW	Single ¹ U-71 S-71			Twin U-140 S-71 S-71
10,0kW		Single ¹ U-100 S-100		
12,5kW			Single ¹ U-125 S-125	
14,0kW				Single ¹ U-140 S-140

PACi Elite from 20,0 to 25,0kW Single/Simultaneous operation system combinations • R410A GAS

Indoor	20,0kW	25,0kW
5,0kW	Double-Twin U-200 S-50 S-50 S-50 S-50	
6,0kW		Double-Twin U-250 S-60 S-60 S-60 S-60
7,1kW	Triple U-200 S-71 S-71 S-71	
10,0kW	Twin U-200 S-100 S-100	
12,5kW		Twin U-250 S-125 S-125
20,0kW	Single ¹ U-200 S-200	
25,0kW		Single ¹ U-250 S-250

1. PACi 1x1 Kit solution.

PACi Standard Outdoor Units • R32 GAS

PACi Elite Outdoor Units • R410A GAS

PACi Standard Outdoor Units • R410A GAS



NEW PACi Standard Outdoor Units • R32 GAS

			10,0kW	12,5kW	14,0kW
Outdoor unit Single Phase			U-100PZ2E5	U-125PZ2E5	U-140PZ2E5
Outdoor unit Three Phase			U-100PZ2E8	U-125PZ2E8	U-140PZ2E8
Cooling capacity	Nominal (Min - Max)	kW	10,00 (3,00 - 11,50)	12,50 (3,20 - 13,50)	14,00 (3,30 - 15,00)
Heating capacity	Nominal (Min - Max)	kW	10,00 (3,00 - 14,00)	12,50 (3,30 - 15,00)	14,00 (3,40 - 16,00)
Power source	Single Phase	V	220 / 230 / 240	220 / 230 / 240	220 / 230 / 240
	Three Phase	V	380 / 400 / 415	380 / 400 / 415	380 / 415
Connection indoor / outdoor		mm ²	—	—	—
Air volume	Cool / Heat	m ³ /min	76,00 / 70,00	86,00 / 78,00	89,00 / 83,00
Sound pressure	Cool / Heat (Hi)	dB(A)	52 / 52	55 / 55	56 / 56
Sound power	Cool / Heat (Hi)	dB	70 / 70	73 / 73	74 / 74
Dimension	HxWxD	mm	996 x 980 x 370	996 x 980 x 370	996 x 980 x 370
Net weight		kg	90	94	94
Piping connections	Liquid pipe	Inch (mm)	3/8 (9,52)	3/8 (9,52)	3/8 (9,52)
	Gas pipe	Inch (mm)	5/8 (15,88)	5/8 (15,88)	5/8 (15,88)
Piping length range	Min ~ Max	m	5 ~ 50	5 ~ 50	5 ~ 50
Elevation difference (in/out)	Max	m	30	30	30
Refrigerant (R410A)		kg/TCO ₂ Eq.	2,60 / 5,4288	3,00 / 2,025	3,00 / 2,025
Operating range	Cool Min ~ Max	°C	-10 ~ +43	-10 ~ +43	-10 ~ +43
	Heat Min ~ Max	°C	-15 ~ +24	-15 ~ +24	-15 ~ +24

PACi Elite Outdoor Units • R410A GAS

			7,1kW	10,0kW	12,5kW	14,0kW	20,0kW	25,0kW
Outdoor unit Single Phase			U-71PE1E5A	U-100PE1E5A	U-125PE1E5A	U-140PE1E5A	—	—
Outdoor unit Three Phase			U-71PE1E8A	U-100PE1E8A	U-125PE1E8A	U-140PE1E8A	U-200PE2E8A	U-250PE2E8A
Cooling capacity	Nominal (Min - Max)	kW	7,10 (2,50 - 8,00)	10,00 (3,30 - 12,50)	12,50 (3,30 - 14,00)	14,00 (3,30 - 15,50)	20,00 (6,00 - 22,40)	25,00 (6,00 - 28,00)
Heating capacity	Nominal (Min - Max)	kW	8,00 (2,00 - 9,00)	11,20 (4,10 - 14,00)	14,00 (4,10 - 16,00)	16,00 (4,10 - 18,00)	21,80 (6,00 - 22,40)	28,00 (6,00 - 31,50)
Power source	Single Phase	V	220 / 240	220 / 240	220 / 240	220 / 240	—	—
	Three Phase	V	380 / 415	380 / 415	380 / 415	380 / 415	380 / 415	380 / 415
Connection indoor / outdoor		mm ²	2 x 1,5 or 2,5	2 x 1,5 or 2,5	2 x 1,5 or 2,5	2 x 1,5 or 2,5	—	—
Air volume	Cool / Heat	m ³ /min	60,00 / 60,00	110,00 / 95,00	130,00 / 110,00	135,00 / 120,00	129,00	118,00
Sound pressure	Cool / Heat (Hi)	dB(A)	48 / 50	52 / 52	53 / 53	54 / 55	57 / 57	57 / 58
Sound power	Cool / Heat (Hi)	dB	65 / 67	69 / 69	70 / 70	71 / 71	72	73
Dimension	HxWxD	mm	996 x 940 x 340	1416 x 940 x 340	1416 x 940 x 340	1416 x 940 x 340	1500 x 980 x 370	1500 x 980 x 370
Net weight		kg	69	98	98	98	118	128
Piping connections	Liquid pipe	Inch (mm)	3/8 (9,52)	3/8 (9,52)	3/8 (9,52)	3/8 (9,52)	3/8 (9,52)	1/2 (12,70)
	Gas pipe	Inch (mm)	5/8 (15,88)	5/8 (15,88)	5/8 (15,88)	5/8 (15,88)	1 (25,40)	1 (25,40)
Piping length range	Min ~ Max	m	5 ~ 50	5 ~ 75	5 ~ 75	5 ~ 75	5 ~ 100	5 ~ 100
Elevation difference (in/out)	Max	m	30	30	30	30	30	30
Refrigerant (R410A)		kg/TCO ₂ Eq.	2,35 / 4,9068	3,40 / 7,0992	3,40 / 7,0992	3,40 / 7,0992	5,60 / 11,6928	6,40 / 13,3632
Operating range	Cool Min ~ Max	°C	-15 ~ +46	-15 ~ +46	-15 ~ +46	-15 ~ +46	-15 ~ +46	-15 ~ +46
	Heat Min ~ Max	°C	-20 ~ +24	-20 ~ +24	-20 ~ +24	-20 ~ +24	-20 ~ +15	-20 ~ +15

PACi Standard Outdoor Units • R410A GAS

			7,1kW	10,0kW	12,5kW	14,0kW
Outdoor unit Single Phase			U-71PEY2E5	U-100PEY1E5	U-125PEY1E5	—
Outdoor unit Three Phase			—	U-100PEY1E8	U-125PEY1E8	U-140PEY1E8
Cooling capacity	Nominal (Min - Max)	kW	7,10 (2,00 - 7,70)	10,00 (2,70 - 11,50)	12,50 (3,80 - 13,50)	14,00 (3,30 - 15,50)
Heating capacity	Nominal (Min - Max)	kW	7,10 (1,80 - 8,10)	10,00 (2,10 - 13,80)	12,50 (3,40 - 15,00)	14,00 (4,10 - 16,00)
Power source	Single Phase	V	220 / 230 / 240	220 / 230 / 240	220 / 230 / 240	—
	Three Phase	V	—	380 / 400 / 415	380 / 400 / 415	380 / 415
Connection indoor / outdoor		mm ²	2,50	4,00	6,00	2,50
Air volume	Cool / Heat	m ³ /min	39,00	76,00 / 67,00	80,00 / 73,00	135,00 / 120,00
Sound pressure	Cool / Heat (Hi)	dB(A)	47 / 49	54 / 54	56 / 56	54 / 53
Sound power	Cool / Heat (Hi)	dB	70 / 70	70 / 70	73 / 73	71 / 70
Dimension	HxWxD	mm	619 x 799 x 299	996 x 940 x 340	996 x 940 x 340	1416 x 940 x 340
Net weight		kg	40	73	85	98
Piping connections	Liquid pipe	Inch (mm)	3/8 (9,52)	3/8 (9,52)	3/8 (9,52)	3/8 (9,52)
	Gas pipe	Inch (mm)	5/8 (15,88)	5/8 (15,88)	5/8 (15,88)	5/8 (15,88)
Piping length range	Min ~ Max	m	5 ~ 50	5 ~ 50	5 ~ 50	5 ~ 50
Elevation difference (in/out)	Max	m	30	30	30	30
Refrigerant (R410A)		kg/TCO ₂ Eq.	1,95 / 4,0716	2,60 / 5,4288	3,20 / 6,6816	3,40 / 7,0992
Operating range	Cool Min ~ Max	°C	-10 ~ +43	-10 ~ +43	-10 ~ +43	-10 ~ +43
	Heat Min ~ Max	°C	-15 ~ +24	-15 ~ +24	-15 ~ +24	-15 ~ +24

PACi Single, Twin, Triple and Double-Twin System

R32 R410A



Optional Controller.
Wired remote controller
CZ-RICS8
Compatible with Econavi



Optional Controller
Wireless remote controller
CZ-RWSK2



Optional Controller.
Simplified remote controller
CZ-RE2C2

Compatible with all Panasonic connectivity solutions. For detailed information go to the Control Systems section.



NEW Wall	Indoor	Cooling capacity	Heating capacity	Dimension		Sound pressure		Air volume	
				H x W x D		Hi / Med / Lo		Hi / Med / Lo	
				mm		dB(A)		m ³ /min	
3,6kW	S-36PK2E5B	3,60	4,20	302 x 1120 x 236		35/31/27		11,00/9,50/7,50	
4,5kW	S-45PK2E5B	4,50	5,20	302 x 1120 x 236		38/34/30		12,00/10,50/8,50	
5,0kW	S-50PK2E5B	5,00	5,60	302 x 1120 x 236		40/36/32		14,00/12,00/10,50	
6,0kW	S-60PK2E5B	6,00	7,00	302 x 1120 x 236		47/44/40		18,00/14,50/11,50	
7,1kW	S-71PK2E5B	7,10	8,00	302 x 1120 x 236		47/44/40		18,00/14,50/11,50	
10,0kW	S-100PK2E5B	10,00	11,20	302 x 1120 x 236		47/44/40		19,00/16,50/13,00	

4 Way 60x60 Cassette	Indoor	Panel	Cooling capacity	Heating capacity	Dimension			Sound pressure	Air volume
					Indoor	Panel CZ-KPY3AW	Panel CZ-KPY3BW		
					H x W x D	H x W x D	H x W x D		
3,6kW	S-36PY2E5A	CZ-KPY3AW/CZ-KPY3BW	3,60	4,20	288 x 583 x 583	31 x 700 x 700	31 x 625 x 625	36/32/26	9,70/9,90
4,5kW	S-45PY2E5A	CZ-KPY3AW/CZ-KPY3BW	4,50	5,20	288 x 583 x 583	31 x 700 x 700	31 x 625 x 625	38/34/28	10,00/10,30
5,0kW	S-50PY2E5A	CZ-KPY3AW/CZ-KPY3BW	5,00	5,60	288 x 583 x 583	31 x 700 x 700	31 x 625 x 625	40/37/33	11,10/11,10

4 Way 90x90 Cassette	Indoor	Panel	Cooling capacity	Heating capacity	Dimension		Sound pressure	Air volume
					Indoor	Panel		
					H x W x D	H x W x D		
3,6kW	S-36PU2E5B	CZ-KPU3/CZ-KPU3A	3,60	4,20	256 x 840 x 840	33,5 x 950 x 950	30/28/27	14,50/13,00/11,50
4,5kW	S-45PU2E5B	CZ-KPU3/CZ-KPU3A	4,50	5,20	256 x 840 x 840	33,5 x 950 x 950	31/28/27	15,50/13,00/11,50
5,0kW	S-50PU2E5B	CZ-KPU3/CZ-KPU3A	5,00	5,60	256 x 840 x 840	33,5 x 950 x 950	32/29/27	16,50/13,50/11,50
6,0kW	S-60PU2E5B	CZ-KPU3/CZ-KPU3A	6,00	7,00	256 x 840 x 840	33,5 x 950 x 950	38/31/28	21,00/16,00/13,00
7,1kW	S-71PU2E5B	CZ-KPU3/CZ-KPU3A	7,10	8,00	256 x 840 x 840	33,5 x 950 x 950	37/31/28	22,00/16,00/13,00
10,0kW	S-100PU2E5B	CZ-KPU3/CZ-KPU3A	10,00	11,20	319 x 840 x 840	33,5 x 950 x 950	45/38/32	36,00/26,00/18,00
12,5kW	S-125PU2E5B	CZ-KPU3/CZ-KPU3A	12,50	14,00	319 x 840 x 840	33,5 x 950 x 950	46/39/33	37,00/27,00/19,00
14,0kW	S-140PU2E5B	CZ-KPU3/CZ-KPU3A	14,00	14,00	319 x 840 x 840	33,5 x 950 x 950	47/40/34	38,00/29,00/20,00

Ceiling	Indoor	Cooling capacity	Heating capacity	Dimension		Sound pressure		Air volume	
				H x W x D		Hi / Med / Lo		Hi / Med / Lo	
				mm		dB(A)		m ³ /min	
3,6kW	S-36PT2E5B	3,60	4,20	235 x 960 x 690		35/32/30		14,00/12,00/10,50	
4,5kW	S-45PT2E5B	4,50	5,20	235 x 960 x 690		38/33/30		15,00/12,50/10,50	
5,0kW	S-50PT2E5B	5,00	5,60	235 x 960 x 690		38/33/30		15,00/12,50/10,50	
6,0kW	S-60PT2E5B	6,00	7,00	235 x 1275 x 690		39/36/33		20,00/17,00/14,50	
7,1kW	S-71PT2E5B	7,10	8,00	235 x 1275 x 690		39/36/33		21,00/18,00/15,50	
10,0kW	S-100PT2E5B	10,00	11,20	235 x 1590 x 690		42/38/35		30,00/25,00/23,00	
12,5kW	S-125PT2E5B	12,50	14,00	235 x 1590 x 690		45/40/37		34,00/28,00/24,00	
14,0kW	S-140PT2E5B	14,00	14,00	235 x 1590 x 690		47/41/37		35,00/29,00/25,00	

High Static Pressure Hide Away	Indoor	Cooling capacity	Heating capacity	Dimension		External static pressure		Sound pressure		Air volume	
				H x W x D		Hi / Me / Lo		Hi / Med / Lo		Hi / Med / Lo	
				mm		Pa		dB(A)		m ³ /min	
3,6kW	S-36PF1E5B	3,60	4,20	290 x 800 x 700		150/70/10		33/29/25		14,00/13,00/10,00	
4,5kW	S-45PF1E5B	4,50	5,20	290 x 800 x 700		150/70/10		34/30/26		14,00/13,00/10,00	
5,0kW	S-50PF1E5B	5,00	5,60	290 x 800 x 700		150/70/10		34/30/26		16,00/15,00/12,00	
6,0kW	S-60PF1E5B	6,00	7,00	290 x 1000 x 700		150/70/10		35/32/26		21,00/19,00/15,00	
7,1kW	S-71PF1E5B	7,10	8,00	290 x 1000 x 700		150/70/10		35/32/26		21,00/19,00/15,00	
10,0kW	S-100PF1E5B	10,00	11,20	290 x 1400 x 700		150/100/10		38/34/31		32,00/26,00/21,00	
12,5kW	S-125PF1E5B	12,50	14,00	290 x 1400 x 700		150/100/10		39/35/32		34,00/29,00/23,00	
14,0kW	S-140PF1E5B	14,00	14,00	290 x 1400 x 700		150/100/10		40/36/33		36,00/32,00/25,00	

Low Static Pressure Hide Away	Indoor	Cooling capacity	Heating capacity	Dimension		External static pressure		Sound pressure		Air volume	
				H x W x D		Hi / Me / Lo		Hi / Med / Lo		Hi / Med / Lo	
				mm		Pa		dB(A)		m ³ /min	
3,6kW	S-36PN1E5A	3,60	4,20	250 x 780 x 650		80/50/10		40/38/35		14,00/14,00	
4,5kW	S-45PN1E5A	4,50	5,20	250 x 780 x 650		80/50/10		41/39/35		16,00/16,00	
5,0kW	S-50PN1E5A	5,00	5,60	250 x 780 x 650		80/50/10		41/39/35		16,00/16,00	
6,0kW	S-60PN1E5A	6,00	7,00	250 x 1000 x 650		80/50/10		43/41/36		22,00/22,00	
7,1kW	S-71PN1E5A	7,10	8,00	250 x 1000 x 650		80/50/10		43/41/36		22,00/22,00	
10,0kW	S-100PN1E5A	10,00	11,20	250 x 1200 x 650		80/50/10		44/42/37		36,00/36,00	
12,5kW	S-125PN1E5A	12,50	14,00	250 x 1200 x 650		80/50/10		46/44/39		38,00/38,00	
14,0kW	S-140PN1E5A	14,00	14,00	250 x 1200 x 650		80/50/10		46/44/39		40,00/40,00	

Rating Conditions: Cooling Indoor 27°C DB / 19°C WB. Cooling Outdoor 35°C DB / 24°C WB. Heating Indoor 20°C DB. Heating Outdoor 7°C DB / 6°C WB. (DB: Dry Bulb; WB: Wet Bulb)
Specifications subject to change without notice. For detailed information about ErP, please visit our websites www.aircon.panasonic.eu or www.ptc.panasonic.eu.

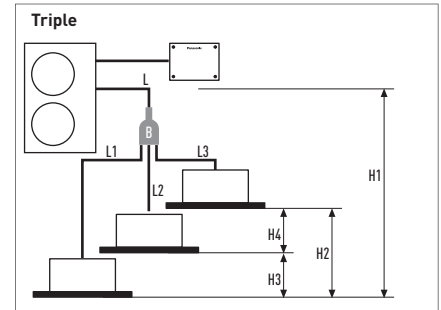
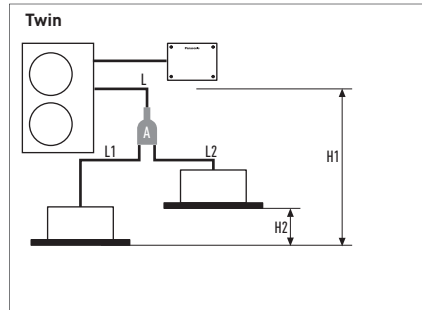
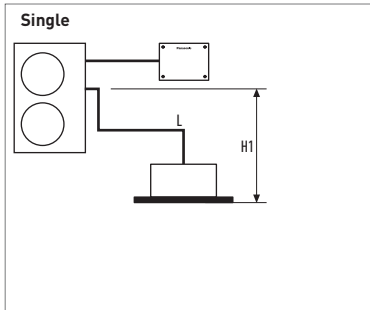

PACi Standard Single and Twin System from 10,0 to 14,0kW

Twin System	Indoor unit combinations (see examples above)		Equivalent lengths and height differences (m) for outdoor unit sizes...
	Single	Twin	
Total pipe length	L	L + L1 + L2	≤ 50m
Maximum pipe length from outdoor unit to most distant indoor unit	-	-	-
Maximum branch pipe length	-	L1 L2	≤ 15
Maximum branch pipe length differences	-	L1 > L2 L1 - L2	≤ 10
Maximum pipe length differences after first branch (Double-Twin)	-	-	-
Maximum pipe length differences after second branch (Double-Twin)	-	-	-
Height difference (outdoor unit located higher)	H1	H1	≤ 30
Height difference (outdoor unit located lower)	H1	H1	≤ 15
Height difference between indoor units	-	H2	≤ 0,5

PACi Standard Single and Twin System from 10,0 to 14,0kW

Twin System	Outdoor unit main pipe diameter (L)		Indoor unit connection tube (L1, L2)	
	Unit type capacity	100	125	50
Liquid pipe (mm)	Ø 9,52	Ø 12,70	Ø 6,35	Ø 9,52
Gas pipe (mm)	Ø 15,88	Ø 15,88	Ø 12,70	Ø 15,88
Additional gas amount (g/m)	50	50	20	50

1. Total capacity of indoor unit connected after the branch

Refrigerant charging: For the twin connection, the amount of refrigerant required for pipe length 30m has been included in this unit at the factory while that required for pipe length 20 m has been included for the Triple / Double-Twin connections. No Additional gas amount is required for the first 30m pipe length in the case of the twin connection and for the first 20m in the case of the Triple / Double-Twin connections. The amount of included refrigerant for each model is listed on NAME PLATE. Make Additional gas amounts by adding up pipe length in an order of main (L branch pipe), (L1, L2, L3 wide diameter) and then selecting the amount of refrigerant corresponding to the remaining (after 30m for the Twin connection and after 20m for the Triple / Double-Twin connections) liquid side pipe diameter and pipe length from the below table.

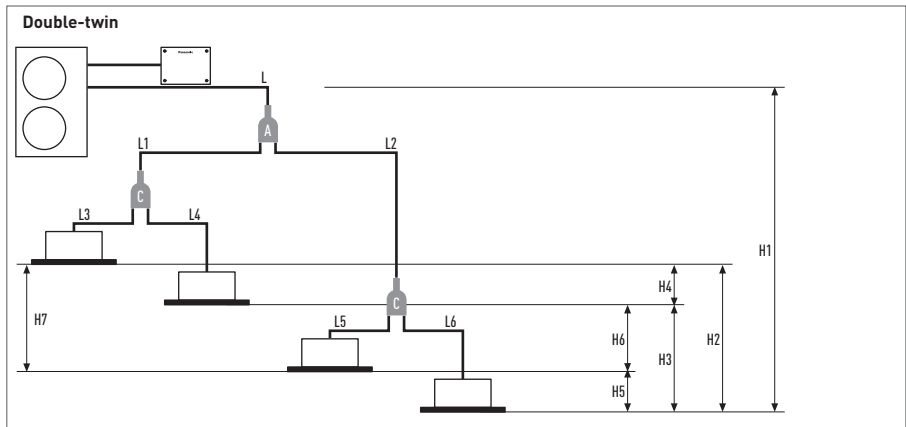

PACi Standard Twin System from 10,0 to 14,0kW
 Joint distribution (sold separately)
 A= CZ-P224BK2BM

PACi Elite Twin, Triple and Double-Twin System from 7,1 to 14,0kW
 Joint distribution (sold separately)
 A= CZ-P224BK2BM
 B= CZ-P3HPC2BM
 C= CZ-P224BK2BM

PACi Elite Twin, Triple and Double-Twin System from 20,0 to 25,0kW
 Joint distribution (sold separately)
 A= CZ-P680BK2BM
 B= CZ-P3HPC2BM
 C= CZ-P224BK2BM

PACi Elite Twin, Triple and Double-Twin System from 7,1 to 25kW

Twin System	Indoor unit combinations (see examples above)				Equivalent lengths and height differences (m) for outdoor unit sizes from 7,1 to 14,0kW	Equivalent lengths and height differences (m) for outdoor unit sizes from 20,0 to 25,0kW
	Single	Twin	Triple	Double-Twin		
Total pipe length	L	L + L1 + L2	L + L1 + L2 + L3	L + L1 + L2 + L3 + L4 + L5 + L6	U-60/U-71: ≤ 50m U-100/125/140: ≤ 75m	≤ 100m
Maximum pipe length from outdoor unit to most distant indoor unit	-	L + L1 or L + L2	L + L1 or L + L2 or L + L3	L + L1 + L3 or L + L1 + L4 or L + L2 + L5 or L + L2 + L6	-	≤ 100m
Maximum branch pipe length	-	L1 or L2	L1 or L2 or L3	L1 + L3 or L1 + L4 or L2 + L5 or L2 + L6	≤ 15m	≤ 20m
Maximum branch pipe length differences	-	L1 > L2: L1 - L2	L1 > L2 > L3: L1 - L2 L2 - L3 L1 - L3	L2 + L6 (Max.) L1 + L3 (Min.): (L2 + L6) - (L1 + L3)	≤ 10m	≤ 10m
Maximum pipe length differences after first branch (Double-Twin)	-	-	-	L2 > L1: L2 - L1	≤ 10m	≤ 10m
Maximum pipe length differences after second branch (Double-Twin)	-	-	-	L4 > L3: L4 - L3 L6 > L5: L6 - L5	≤ 10m	≤ 10m
Height difference (outdoor unit located higher)	H1	H1	H1	H1	≤ 30m	≤ 30m
Height difference (outdoor unit located lower)	H1	H1	H1	H1	≤ 15m	≤ 15m
Height difference between indoor units	-	H2	H2 or H3 or H4	H2 or H3 or H4 or H5 or H6	≤ 0,5m	≤ 0,5m

PACi Elite Twin, Triple and Double-Twin System from 7,1 to 14,0kW

PACi Elite Twin, Triple and Double-Twin System from 20,0 to 25,0kW

Twin System	PACi Elite Twin, Triple and Double-Twin System from 7,1 to 14,0kW						PACi Elite Twin, Triple and Double-Twin System from 20,0 to 25,0kW				
	Outdoor unit main pipe diameter (L)	Indoor unit connection pipe diameter (L1, L2, L3, L4) (mm)					Outdoor unit main pipe diameter (L) (mm)	Double-Twin distribution pipe (L1, L2) ¹	Indoor unit connection pipe diameter		
Unit type capacity	71 - 140	36	45	50	60	71	200	250	100 - 125	50	60 - 125
Liquid pipe (mm)	Ø 9,52	Ø 6,35	Ø 6,35	Ø 6,35	Ø 9,52	Ø 9,52	Ø 9,52	Ø 12,70	Ø 9,52	Ø 6,35	Ø 9,52
Gas pipe (mm)	Ø 15,88	Ø 12,70	Ø 12,70	Ø 12,70	Ø 15,88	Ø 15,88	Ø 25,40	Ø 25,40	Ø 15,88	Ø 12,70	Ø 15,88
Additional gas amount (g/m)	50	20	20	20	50	50	40	80	40	20	40

1. Total capacity of indoor unit connected after the branch

Refrigerant charging: For the twin connection, the amount of refrigerant required for pipe length 30m has been included in this unit at the factory while that required for pipe length 20 m has been included for the Triple / Double-Twin connections. No Additional gas amount is required for the first 30m pipe length in the case of the twin connection and for the first 20m in the case of the Triple / Double-Twin connections. The amount of included refrigerant for each model is listed on NAME PLATE. Make Additional gas amounts by adding up pipe length in an order of main (L branch pipe), (L1, L2, L3 wide diameter) and then selecting the amount of refrigerant corresponding to the remaining (after 30m for the Twin connection and after 20m for the Triple / Double-Twin connections) liquid side pipe diameter and pipe length from the below table.

PANASONIC VENTILATION SOLUTIONS



Panasonic ventilation solutions for maximum savings and easy integration.

AHU Kit connects PACi outdoor units to Air Handling Units system¹

Heat exchanger, Fan & Fan motor to be mounted in AHU Kit shall be provided in the field.

AHU connection Kit (field supplied) AHU Kit system. (Contents of kit: Control for PCB, expansion valve, sensors).



Application: Hotels, offices, server rooms or all large buildings where air quality control such as humidity control and fresh air and is needed.

AHU Kit combine air conditioning and fresh air in just one solution.

The Panasonic AHU Kits offer a wealth of connectivity possibilities so can be easily integrated into many systems.

Besides the advantages in terms of indoor air quality, air conditioning offers also an energy saving potential. For example, while uncontrolled ventilation through open windows leads to large amounts of heat being lost to the outside during the heating season or gained from the outside during the cooling season, air conditioning systems provide possibilities to utilize the extra "free" energy in heat recovery modules so that overall operating costs will be reduced.

The larger the area of the comfort range, the better the energy saving opportunities.

¹) Connectable to R32 or R410A. Compatible with R32 models. Special setting is required.

Air Curtain with DX Coil¹

Highly efficient heating effect

The combined air stream, which has a desirable low air current induction factor (mixing factor), can carry the selected initial temperature effect over long distances, and will reach the floor area while still at room temperature. This is necessary to avoid cooling down the interior spaces.



The Panasonic range of air curtains is designed for smooth operation and efficient performance. Air curtains produce a continuous stream of air blown from the top to the bottom of an open doorway and create a barrier that people and products can flow across, but air can't. Designed to improve energy efficiency, minimise heat loss from a building, and to allow retailers to keep doors open to encourage customers, our Air Curtains are suitable for connection to both VRF and PACi Systems.

Heating capacity comparison: Electrical air curtain / Panasonic air curtain

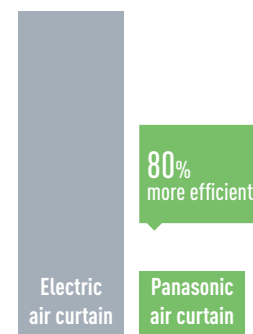

* With the U-100PE1E5A on the PAW-20PAIRC-MS. Calculation method: Taking as consideration SCOP of the Panasonic combination of 6.0. If 100 is the energy needed for a air curtain, Panasonic Air curtain will need 1/(1-6)*100=20.

NEW ELECTRIC AIR CURTAIN

1 Newly designed to maximize performance

High Air volume upgraded 145% compared to conventional model (in the case of FY-3009U1).

2 Comprehensive product line up

1,5m wide model added in the line up.

3 Easier installation & maintenance

Simple structure for easy installation & maintenance.



		FY-3009U1	FY-3012U1	FY-3015U1
Width	mm	900	1200	1500
Voltage	V	220	220	220
Air volume	Hi / Lo m ³ /h	1100/920	1400/1270	2000/1800
Consumption	Hi / Lo W	76/70	94/85	131/110
Current	Hi / Lo A	0,35/0,32	0,43/0,40	0,59/0,50
Air speed	Hi / Lo m/s	10,50/8,50	9,50/8,00	10,50/9,50
Dimension	H x W x D mm	900 x 231,5 x 212	1200 x 231,5 x 212	1500 x 231,5 x 212
Weight	kg	12,0	14,5	18,0
Sound pressure	dB(A)	48,5/45,0	48,5/44,5	51,5/48,0

AIR HANDLING UNIT KIT 10-25kW FOR PACi. COMPATIBLE WITH R32 OR R410A OUTDOOR UNITS



Panasonic AHU Kit, 10-25kW connected to PACi outdoor unit

The Air Handling Unit Kit has been developed to better meet customer demand: IP 65 Box in order to be installed outside, 0-10V demand control* and easy control by BMS

* Only available with Elite PACi, up to from 6kW to 14kW.

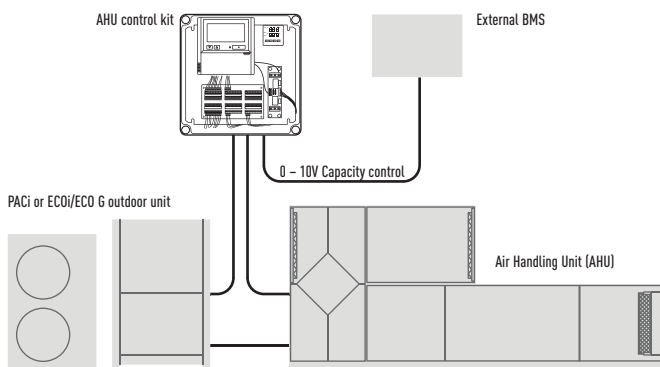

Demand control on the outdoor unit managed by external 0-10 V signal.

Control option 1: PAW-280PAH2L

- The system's control is simple: control of actual suction temperature vs. set point
- Control works in the same way as that of any indoor unit
- Fan signal issued by the PCB (OFF while defrosting, for instance)

Control option 2: PAW-280PAH2

- System control by probe located at air intake. Sensor works as a 0-10V control thermostat which manages the set point temperature. Control to prevent cold draughts.
- All signals as per standard

Control option 3: PAW-280PAH2

- System control by external environment probe. Sensor works as a 0-10V control thermostat which manages the set point temperature. Enhances efficiency by adjusting capacity to the ambient temperature and enhances comfort as well.
- All signals as per standard

Control option 4: PAW-280PAH2

- System control by a 0-10V control working from an external BMS that manages the set point for the temperature or the capacity. Enhances efficiency by adjusting capacity to the ambient temperature and enhances comfort as well.
- All signals as per standard

Main components of mechanical ventilation systems

The main components of a mechanical ventilation system are the following: Air Handling Unit (AHU), air ducts and air distribution elements.

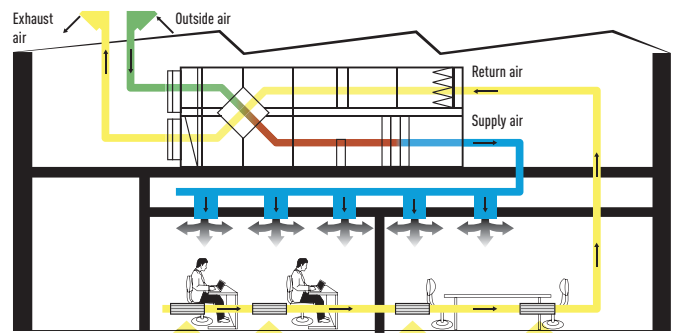

0-10V control

With the 0-10 v demand control the capacity of the outdoor unit can be controlled by 20 steps.

With the included resistance. 0-10V control scheme with 10V= maximum capacity

Input Voltage* (V)	0 - 0,55	1,1	1,65	2,2	2,8	3,35	3,9	4,45	5,0	5,55	6,1	6,65	7,2	7,8	8,35	8,9	9,45	10,0
Demand (% of nominal current)	Stop ¹	40	45	50	55	60	65	70	75	80	85	90	95	100	105	110	115	No limit / Full capacity ³

When you remove the resistance. 0-10V control scheme with 10V= Thermo-Off

Input Voltage* (V)	0 - 0,5	1,0	1,5	2,0	2,5	3,0	3,5	4,0	4,5	5,0	5,5	6,0	6,5	7,0	7,5	8,0	8,5	9,0	9,5 - 10,0
Demand (% of nominal current)	Stop ¹	40	45	50	55	60	65	70	75	80	85	90	95	100	105	110	115	No limit ²	Thermo-Off ³

* If a voltage range (0 - 0,5 or 9,5 - 10,0V) is indicated, the applied voltage must be within the given limits.

However, if a single value (e.g. 1,0V) is indicated, the applied voltage must be within +/-0,1V of the given value to achieve the assigned demand setting.

Examples: "Stop" can be achieved with any analogue input value greater than 0V and less than or equal to 0,5 V; 40% demand can be achieved with any analogue input value greater than or equal to 0,9V and less than or equal to 1,1V etc.

1) Stop: AHU system / indoor unit is completely switched off.

2) No Limit: No restrictions applied by BMS to AHU system / indoor unit performance (equivalent to "full-load operation" of AHU system / indoor unit).

3) Thermo-Off: No cooling / heating operation (compressor is switched off; however, the fans may still be operating). For example, forced Thermostat-Off mode can be used for free cooling.

AHU Kit connects PACi outdoor units to Air Handling Units system.
 The Panasonic AHU Kits offer a wealth of connectivity possibilities so can be easily integrated into many systems.
 Application: Hotels, offices, server rooms or all large buildings where air quality control such as humidity control and fresh air and is needed.

3 types of AHU Kit: Deluxe, Medium and Light.

Model Code	IP 65	0-10V demand control*	Outdoor temperature shift compensation. Cold draft prevention
PAW-280PAH2	Yes	Yes	Yes
PAW-280PAH2M	Yes	Yes	No
PAW-280PAH2L	Yes	No	No

* With CZ-CAPBC2.

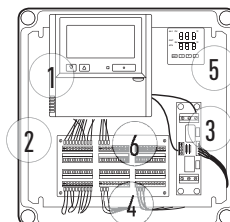

1. Remote control CZ-RTC4
2. New plastic IP 65 Box
3. PAW-T10 PCB for dry contact
4. 0-10V demand control PCB
5. Intelligent thermostat for:
 - Cold draft prevention
 - Outdoor temperature shift compensation
6. Terminal base for sensors and power supply

System & regulations. System overview

1. AHU Kit equipment (Field supplied)
2. AHU Kit system controller (Field supplied)
3. AHU Kit controller box (with control PCB)
4. Thermistor for Gas pipe (E2)
5. Thermistor for Liquid pipe (E1)
6. Thermistor for Suction pipe air
7. Inter-unit wiring
8. Outdoor unit

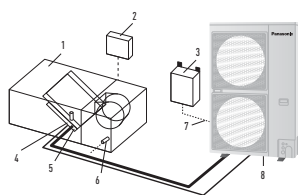

AHU Connection Kit



PCB, Power trans, Terminal block



Thermistor x2 (Refrigerant: E1, E2)



Thermistor (Air: TA; 1 sensor)



Standard wired remote controller.

Optional parts: Following functions are available by using different control accessories:

CZ-RTC4 Timer remote controller.

- Operation-ON/OFF
- Mode select
- Temperature setting

* Fan operation signal can be taken from the PCB.

PAW-OCT, DC12 V outlet. OPTION terminal.

- Output signal= Cooling/Heating/Fan status
- Defrost
- Thermostat-ON

CZ-CAPBC2 Mini seri-para I/O unit (advanced version only).

- Easy integration in external AHU control systems and BMS
- Demand control: 40 to 115 % [5 % steps] of nominal current by 0-10 V input signal*
- Target temperature setting by 0-10 V or 0-140 Ω input signal*
- Room supply air temperature output by 4-20 mA signal
- Mode select or/and ON/OFF control
- Fan operation control
- Operation status output/ Alarm output
- Thermostat ON/OFF control

* Demand control by external BMS cannot be combined with the demand control or target temperature setting accomplished by the thermostat. However, if simultaneous demand control and target temperature setting is needed, this can only be achieved by using a second (optional) CZ-CAPBC2 interface.

CZ-T10 terminal / PAW-T10 PCB to connect to T10 connector.

- A Dry contact PCB has been developed to easily control the unit
- Input signal operation ON/OFF
- Remote control prohibition
- Output signal Operation ON status maximum 230 V 5 A (NO/NC)
- Output signal alarm status max. 230 V 5 A (NO/NC)
- Alarm output (by DC12V)
- Additional available contacts:
 - External humidifier control (ON/OFF) 230 VAC 3 A
 - External fan control (ON/OFF) 12V DC
 - External filter status signal potential free
 - External float switch signal potential free
 - External leakage detection sensor or TH. OFF contact potential free (possible usage for external blow out temperature control)

AHU PACi Elite	Cooling capacity	Heating capacity	Air volume	Dimensions	Piping length	Elevation difference (in/out)
	Nominal kW	Nominal kW	High / Low m³/min	HxBxD mm	Min / Max m	Min / Max m
PAW-280PAH2	6,00 / 25,00	7,00 / 28,00	8,00 / 74,00	404x425x78	5 / 30*	10
PAW-280PAH2+PAW-280PAH2	50,00	56,00	38,00 / 148,00	404x425x78	5 / 30*	10

* For U-200PEZE8A and U-250PEZE8A.

AHU connection kit / System combination	Outdoor unit capacity	AHU	Air volume	Dimensions	Piping length	Elevation difference (in/out)	Piping connections	
			High / Low m³/min	HxBxD mm	Min / Max m	Min / Max m	Liquid pipe Tum (mm)	Gas pipe Tum (mm)
5,0kW	PAW-280PAH2	PAW-280PAH2	8,00 / 13,00	404x425x78	5/30	10	1/4 (6,35)	1/2 (12,70)
6,0kW	PAW-280PAH2	PAW-280PAH2	9,00 / 16,00	404x425x78	5/30	10	3/8 (9,62)	5/8 (15,88)
7,5kW	PAW-280PAH2	PAW-280PAH2	12,00 / 25,00	404x425x78	5/30	10	3/8 (9,62)	5/8 (15,88)
10,0kW	PAW-280PAH2	PAW-280PAH2	14,00 / 33,00	404x425x78	5/30	10	3/8 (9,62)	5/8 (15,88)
12,5kW	PAW-280PAH2	PAW-280PAH2	19,00 / 35,00	404x425x78	5/30	10	3/8 (9,62)	5/8 (15,88)
14,0kW	PAW-280PAH2	PAW-280PAH2	19,00 / 35,00	404x425x78	5/30	10	3/8 (9,62)	5/8 (15,88)
20,0kW	PAW-280PAH2	PAW-280PAH2	28,00 / 66,00	404x425x78	5/70	10	3/8 (9,62)	1 (25,40)
25,0kW	PAW-280PAH2	PAW-280PAH2	38,00 / 74,00	404x425x78	5/70	10	1/2 (12,70)	1 (25,40)

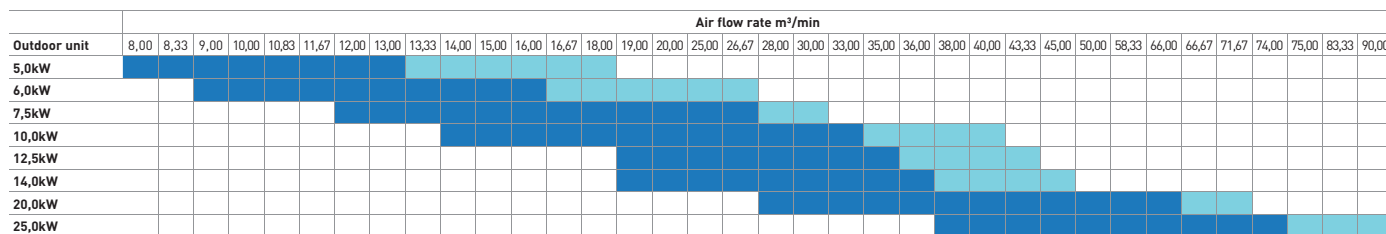

Standard condition in cooling mode intake air temperature. Rating Conditions: Cooling Indoor 27°C DB / 19°C WB.

Maximum condition in cooling mode intake air restriction temperature Min18°C DB / 13°C WB Max 32°C DB / 23°C WB

AIR CURTAIN WITH DX COIL, CONNECTED TO THE VRF OR PACi SYSTEMS. COMPATIBLE WITH R32 OR R410A OUTDOOR UNITS

Highly efficient heating effect

The combined air stream, which has a desirable low air current induction factor (mixing factor), can carry the selected initial temperature effect over long distances, and will reach the floor area while still at room temperature. This is necessary to avoid cooling down the interior spaces. Available in different lengths to suit requirements between 1 and 2,5m, both air curtains have outlet grilles that can be adjusted to five different positions. The jet flow model can be installed up to a height of 3,5m with the standard model up to 3,0m. The outlet grilles can be easily adjusted into five positions to suit different installations requirements and the air filter can be accessed without the need for specialist tools.

- High performance with EC fan motor (40% lower running costs compared to a standard AC fan motor)
- Easy Cleaning and Servicing
- Can be connected to either Panasonic VRF or PACi systems
- Built-in drain for cooling operation
- Standard and Jet Flow air curtains can be controlled via Panasonic's range of remote internet controls

The standard and jet-flow models are ideal for connection to a ECOi or PACi system. With simple "plug and play" installation, both are fitted with an EC fan motor for a smooth operation and efficient performance. This fan guarantees 40% lower running cost than with a standard AC fan motor. Air curtains run approximately 12 hours per day at shops, and efficient performance contributes to energy savings.

Internet Control

An app added to your tablet or smartphone or via the Internet allows you to control and manage the system remotely. There is also the option to integrate into existing BMS systems by using other Panasonic interfaces.

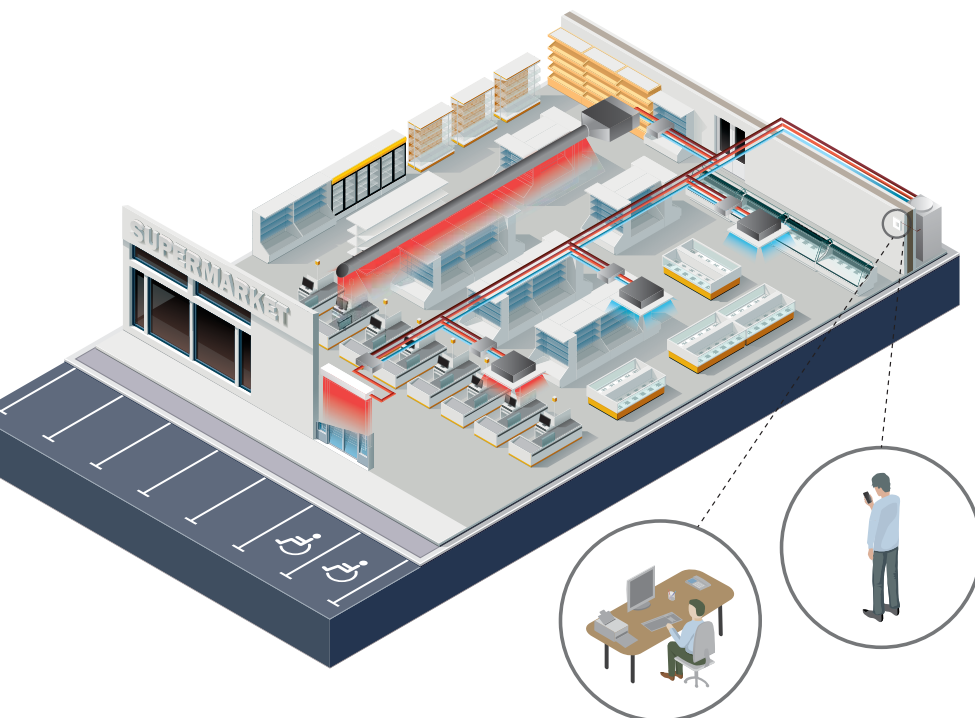

Intelligent Operation

Our air curtains combine airflow and heating / cooling technology to ensure optimum comfort and energy efficiency whilst also creating an effective barrier between indoor and outdoor environments. Design and installation is key to achieving the correct height / temperature settings to achieve optimum performance. Our air curtains are designed to answer the demands of the retail, commercial and industrial markets.

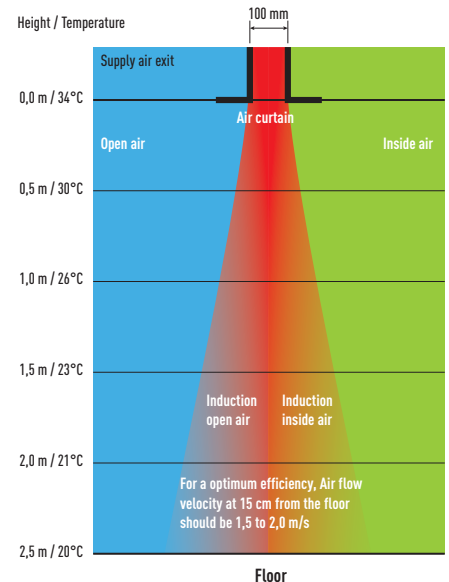

How does it work?

Stale air from the room is taken in and ejected near the door. This creates a 'roll of air' that shields the door area, mixing with the colder incoming air. It then turns away from the door, back into the room and toward the intake screen, where it is partly drawn in again. This flow of air helps to create a barrier for heat loss yet at the same time refreshes room air

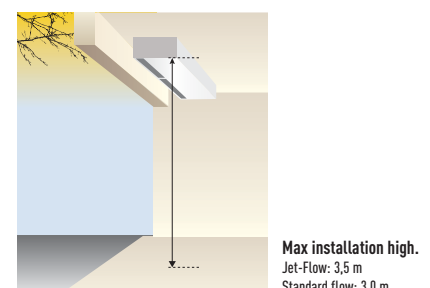

High efficiency air curtain connected to your VRF installation. EC Fan motor for a smooth operation and efficient performance. 2 types of air flow available: Jet-Flow and Standard. Easy cleaning and servicing.



Technical focus

- Save up to 40% energy costs by use of the integrated EC fan technology (higher efficiency than conventional AC fan, soft start and longer motor duration)
- 3 lengths of air curtains Jet-Flow, from 1,0 to 2,0 m and 2 lengths of air curtains Standard, 1,0 and 2,0 m
- Installation height up to 3,5 m (Jet-Flow) and 3,0 m (Standard)
- Outlet grilles can be adjusted in five positions, to suite different indoor and installation requirements (Jet-Flow)
- Control with Panasonic remote control systems (optional)
- Direct integration to BMS by optional Panasonic interfaces
- Drain included for cooling operation

Features

Comfort.

- Easy redirection of Airflow by means of manual deflector (Jet-Flow)

Ease of use.

- Speed selector (high and low) on the unit itself

Easy installation and maintenance.

- Easy installation
- Compact dimensions improve installation and positioning (Jet-Flow)
- Easy cleaning of grid without opening of the unit

Optimised airflow velocity

1. Energy losses, no air curtain installed
2. Too low velocity air curtain – air curtain not efficient
3. Optimum results with the Tekadood air curtain connected to Panasonic VRF
4. Too high velocity air curtain – considerable turbulence, energy lost to the outside, air curtain not efficient

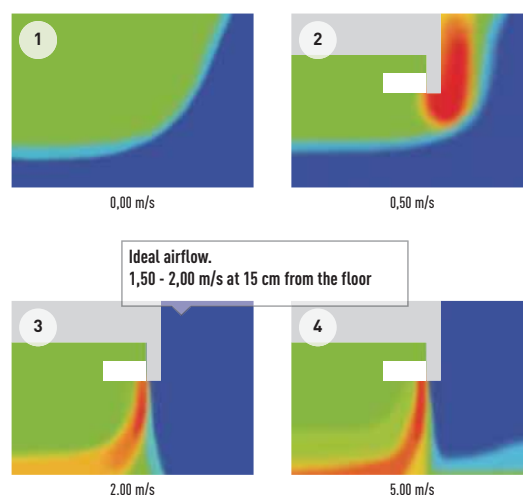

HP			4HP	6HP	8HP	4HP	8HP
Air Curtain			PAW-10PAIRC-MJ	PAW-15PAIRC-MJ	PAW-20PAIRC-MJ	PAW-10PAIRC-MS	PAW-20PAIRC-MS
Air Flow type			Jet-Flow			Standard	
Air Flow length (A)	m		1,0	1,5	2,0	1,0	2,0
Air volume	High / Medium / Low	m ³ /min	30,00/25,00/20,00	45,00/38,30/31,70	60,00/50,00/41,70	30,00/25,00/20,00	45,00/38,30/31,70
Cooling capacity ¹		kW	9,2	17,5	23,1	9,2	17,5
Heating capacity with air in 20°C, air out 40 / 35 / 30°C		kW	11,90/8,90/5,90	17,90/13,40/8,90	23,90/17,90/11,90	11,90/8,90/5,90	17,90/13,40/8,90
Max installation height	Good / Normal / Bad	m	3,50/3,10/2,70	3,50/3,10/2,70	3,50/3,10/2,70	3,00/2,70/2,40	3,00/2,70/2,40
Refrigerant			R410A	R410A	R410A	R410A	R410A
Liquid pipe		Inch (mm)	3/8(9,52)	3/8(9,52)	3/8(9,52)	3/8(9,52)	3/8(9,52)
Gas pipe		Inch (mm)	5/8(15,88)	3/4(19,05)	7/8(22,22)	5/8(15,88)	7/8(22,22)
Fan			230V/50Hz/1/N/PE	230V/50Hz/1/N/PE	230V/50Hz/1/N/PE	230V/50Hz/1/N/PE	230V/50Hz/1/N/PE
Fan type			EC	EC	EC	EC	EC
Currency	High / Med / Low	A	2,10/0,80/0,30	2,80/1,10/0,40	4,20/1,60/0,60	2,10/0,80/0,30	4,20/1,60/0,60
Electrical Consumption	High / Med / Low	kW	0,44/0,17/0,06	0,59/0,23/0,08	0,89/0,34/0,12	0,44/0,17/0,06	0,89/0,34/0,12
Protecting Fuse		A	M16A	M16A	M16A	M16A	M16A
Noise		dB(A)	40-55	40-56	40-57	40-55	40-57
Dimension / Net weight	H x W x D	mm / kg	260 x 1210 x 590 / 70	260 x 1710 x 590 / 100	260 x 2210 x 590 / 138	260 x 1210 x 490 / 60	260 x 2210 x 490 / 128
PACi Elite with air out 40°C			10,0kW	14,0kW	20,0kW	10,0kW	14,0kW
PACi Standard with air out 40°C			10,0kW	—	—	10,0kW	—
PACi Elite with air out 35°C			7,1kW	10,0kW	14,0kW	7,1kW	10,0kW
PACi Standard with air out 35°C			10,0kW	10,0kW	—	10,0kW	10,0kW
PACi Elite with air out 30°C			5,0kW	10,0kW	10,0kW	5,0kW	10,0kW
PACi Standard with air out 30°C			6,0kW	10,0kW	10,0kW	6,0kW	10,0kW

All combinations under rated conditions: Heating Outdoor +7°C DB/+6°C WB Indoor +20°C DB. In case of lower outdoor temperatures a higher capacity outdoor unit model may be necessary. 1) Rated Conditions Cooling Outdoor +35°C DB Indoor +27°C DB/+19°C WB, Discharge temperature ³ 16°C.



R22 RENEWAL FAST, EASY TO INSTALL AND COST EFFECTIVE



¡An important drive to further reduce the potential damage to our ozone
It is often said that legislation is ruling our lives but sometimes it is there to help save
lives. R22 phase out can be described as one of these and from Jan 1st 2010 the use of
Virgin (new) R22 refrigerant was banned within the European Union.

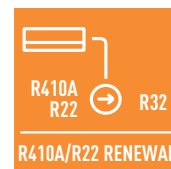

Panasonic are doing our part

We at Panasonic are also doing our part – recognising that all finances are under pressure at the moment. Panasonic has developed a clean and cost effective solution to enable this latest legislation to offer less financial impact on your business as much as possible. The Panasonic renewal system allows good quality existing R22 pipe work to be re-used whilst installing new high efficiency R410A / R32 systems. By bringing a simple solution to the problem Panasonic can renew all Split Systems and PACi systems; and depending upon certain restrictions we don't even limit the manufacturer's equipment we are replacing. By installing a new high efficiency Panasonic R410A / R32 system you can benefit from around 30% running cost saving compared to the R22 system.

Yes...

1. Check the capacity of the system you wish to replace
 2. Select from the Panasonic range the best system to replace it with
 3. Follow the procedure detailed in the brochure and technical data
- Simple...



Why renewal?

Unique R22 Renewal from Panasonic: Fast, easy to install and cost effective.

- Panasonic refrigerant oil doesn't react to the most common oil types used in air-conditioning systems. This ensures the mix of oil does not damage the units. Therefore installations are easier

- All Panasonic PACi units can be installed in R22 pipings, no specific models are available
- Up to 33 Bar! When there is any doubt about the strength of the piping, the maximum working pressure can be reduced to 33 Bar with a setting in the software of the outdoor unit

Reuse of existing piping (renewal design & installation)

Notes on reuse of existing refrigerant piping.

It is possible for each series of PE1 / PE2 type and PEY2 an PZ type outdoor unit to reuse the existing refrigerant piping without cleaning when obtained under certain conditions. Make sure that the requirements under the section "Notes on reuse of existing refrigerant piping", "Measurement procedure for renewal" and "Refrigerant piping size and allowable piping length" will be satisfied in order to carry out.

Also, check the items with regard to section "Safety" and "Cleaning".

1. Prerequisite

- If the refrigerant used for the existing unit is other than R22, R407C and R410A / R32, the existing refrigerant piping cannot be used.
- If the existing unit has another use than air conditioning, then existing refrigerant piping cannot be used.

2. Safety

- If there is a hollow, crack or corrosion on the piping, make sure to install new piping.
- If the existing piping is other than capable of reuse of piping as shown in the flowchart, make sure to install new piping.

- In case of multiple operation, use our genuine branch piping for refrigerant R410A / R32.

A local supplier shall assume responsibility for the defects and hollows on the reuse of existing piping surface and recognition of reliability of the piping strength. There is no guarantee that we take responsibility for such damages. The operational pressure of the refrigerant R410A / R32 becomes higher compared to R22. In the worst case, a lack of compressive strength may lead to piping explosion.

3. Cleaning

- When the refrigerant oil used for the existing unit is other than the listed below, make sure to install new piping or wash it thoroughly before reusing it.
[Mineral Oil] SUNISO, FIORE S, MS
[Synthesized oil] alkyl benzene oil (HAB, parallel freeze), ester oil, ether oil (PVE only)

If the existing unit is GHP type, it is necessary to wash the piping thoroughly.

- If the existing pipes in the outdoor and indoor units remain disconnected, make sure to install a new piping or wash it thoroughly before reusing it.
- If the discoloured oil or residue remains in the existing piping, make sure to install a new piping or wash it thoroughly before reusing it. See "Deterioration Criteria for Refrigerant Oil" in table 3.
- If the compressor of the existing air conditioner has a failure history, make sure to install a new piping or wash it through thoroughly before reusing it.

When reusing the existing piping as it is without removing dirt and dust, inadequate piping could result a renewal appliance in failure.

Notes on renewal for simultaneous operation of multiple units

Only main pipe is applicable for using the different diameter size.
 In case of different diameter size for the branch pipes, a new installation work for a standard size is necessary.
 Be sure to use our genuine branch piping for refrigerant R410A / R32.

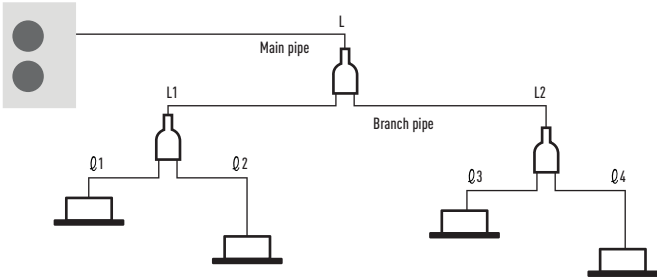

Notes on renewal for simultaneous operation of multiple units

Capacity class	Standard liquid pipe size	Standard gas pipe size
Type 50	∅ 6,35	∅ 12,70
Type from 60 to 140	∅ 9,52	∅ 15,88
Type 200	∅ 9,52	∅ 25,40
Type 250	∅ 12,70	

- Only the main pipe L can be used among different diameter's existing piping
- Installation work as a standard size is capable for L1, L2, l1 - l4 piping
- Be sure to use our genuine branch piping for refrigerant R410A / R32

1. In case of single unit:
 It is not necessary to charge with additional refrigerant until the chargeless pipe length in the table 2.
 If the pipe length is exceeding the charge less pipe length, charge with additional refrigerant amount per 1m according to the equivalent length.
2. In case of simultaneous operation of multiple units:
 Calculate the refrigerant charging amount according to the calculating method of the standard piping diameter.
 As to the additional refrigerant charging amount per 1m, refer to the additional amount in the table 2.

Measurement procedure for Renewal

Observe the following procedure when reusing the existing piping or carrying out renewal installation work.
 Flowchart of existing piping measures criteria for PE1 Type and PEY1 type outdoor unit.

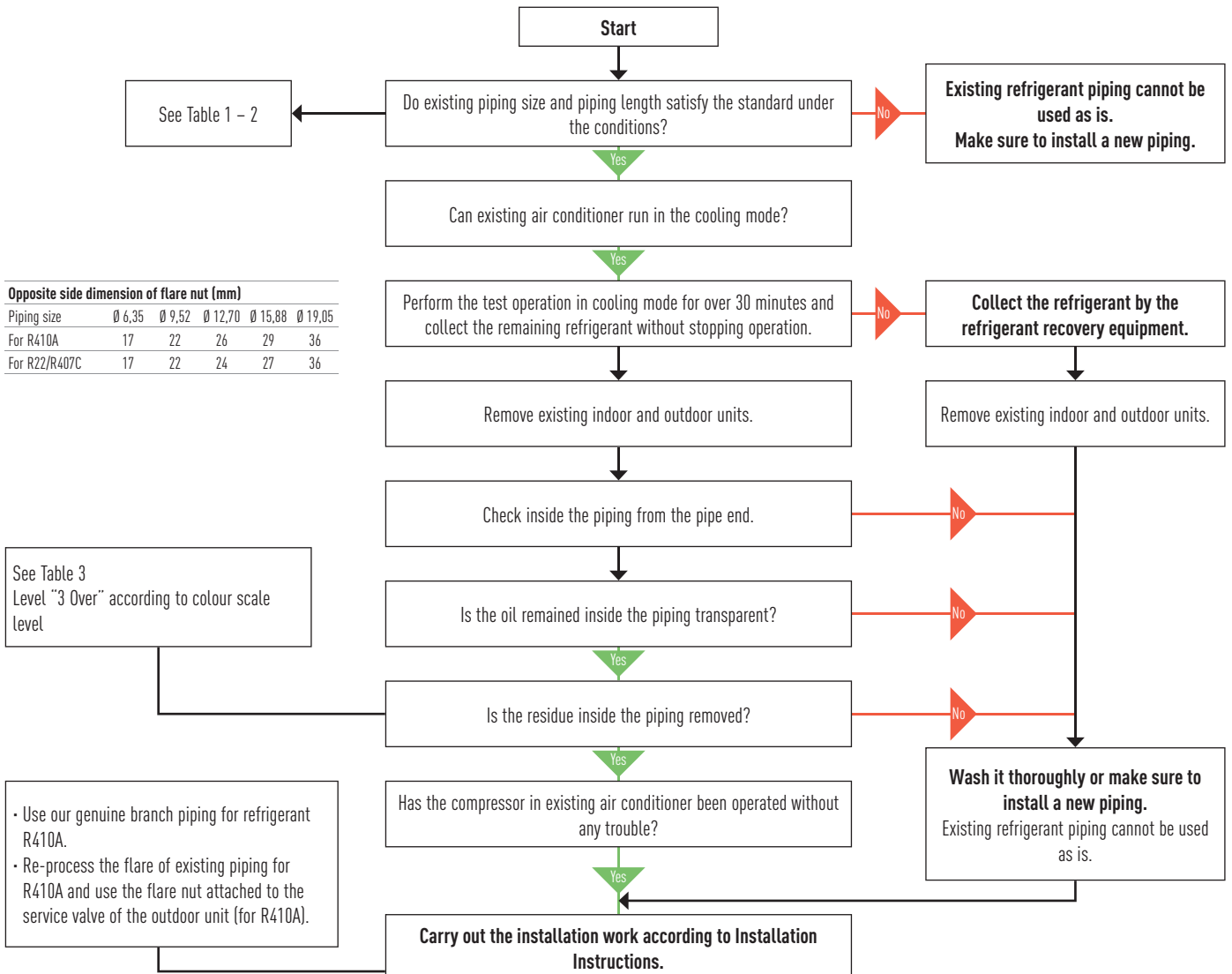

Opposite side dimension of flare nut (mm)

Piping size	∅ 6,35	∅ 9,52	∅ 12,70	∅ 15,88	∅ 19,05
For R410A	17	22	26	29	36
For R22/R407C	17	22	24	27	36

See Table 3
 Level "3 Over" according to colour scale level

- Use our genuine branch piping for refrigerant R410A.
- Re-process the flare of existing piping for R410A and use the flare nut attached to the service valve of the outdoor unit (for R410A).

Refrigerant piping size and allowable piping length

Check if reuse of existing refrigerant piping is possible based on the following chart.

The standards other than this one (difference of elevation, etc.) are identical to the requirements of ordinary refrigerant piping.

Table 1 Reusable existing piping (mm)

Material	0				1/2 H, H*			
External diameter	Ø 6,35	Ø 9,52	Ø 12,70	Ø 15,88	Ø 19,05	Ø 22,22	Ø 25,40	Ø 28,58
Thickness	0,80	0,80	0,80	1,00	1,00	1,00	1,00	1,00

* It is impossible to reuse the size of Ø 19.05, Ø 22.22, Ø 25.4 and Ø 28.58 for material 0. Change to material 1/2H or material H.

Table 2 - 1 Refrigerant piping size: 3,6 - 14,0 kW type (mm)

Liquid pipe	Ø 6,35			Ø 9,52			Ø 12,70		
Gas pipe	Ø 9,52	Ø 12,70	Ø 15,88	Ø 12,70	Ø 15,88	Ø 19,05	Ø 15,88	Ø 19,05	
PE / PZH	Type 50	Standard 40 m (30 m)	⊙ 40 m (30 m)	□ 20 m (15 m)	□ 20 m (15 m)	×	×	×	
PEY / PZ	Type 60 Type 71	▽ 10 m (10 m)	□ 10 m (10 m)	▽ 30 m (20 m)	Standard 50 m (20 m)	×	□ 25 m (10 m)	×	
Additional refrigerant charging amount per 1 m		20 g/m			40 g/m			80 g/m	
PE / PZH	Type 60 Type 71	×	▽ 10 m (10 m)	□ 10 m (10 m)	▽ 30 m (30 m)	Standard 50 m (30 m)	×	□ 25 m (15 m)	×
	Type 100 Type 125 Type 140	×	×	×	×	Standard 75 m (30 m)	⊙ 75 m (30 m)	□ 35 m (15 m)	□ 35 m (15 m)
PEY / PZ	Type 100 Type 125 Type 140	×	×	×	×	Standard 50 m (30 m)	⊙ 50 m (30 m)	□ 25 m (15 m)	□ 25 m (15 m)
Additional refrigerant charging amount per 1 m		20 g/m			50 g/m			80 g/m	

How to see table definition (example):

In case of type 71, standard size is liquid pipe Ø 9,52 / gas pipe Ø 15,88,

There is a limitation to liquid pipe Ø 9,52 / gas pipe Ø 12,70 and to liquid pipe Ø 12,70 / gas pipe Ø 15,88,

However, they are applicable for different diameter's pipes.

Table 2 - 2 Refrigerant piping size: 20,0 - 25,0 kW type (mm)

Liquid pipe	Ø 9,52			Ø 12,70			Ø 15,88			
Gas pipe	Ø 22,22	Ø 25,40	Ø 28,58	Ø 22,22	Ø 25,40	Ø 28,58	Ø 22,22	Ø 25,40	Ø 28,58	
PE	Type 200	▽ 80 m (30 m)	Standard 100 m (30 m)	⊙ 100 m (30 m)	▽ 50 m (15 m)	□ 50 m (15 m)	□ 50 m (15 m)	×	×	×
	Type 250	×	×	×	▽ 80 m (30 m)	Standard 100 m (30 m)	⊙ 100 m (30 m)	▽ 65 m (20 m)	□ 65 m (20 m)	□ 65 m (20 m)
Additional refrigerant charging amount per 1 m		40 g/m			80 g/m			120 g/m		

- ⊙ Allowable
- ▽ Cooling capacity down
- Limited piping length
- ×
- 50 m Maximum piping length
- (50 m) Charge less piping length in a single connection

Table 3 Deterioration Criteria for Refrigerant Oil

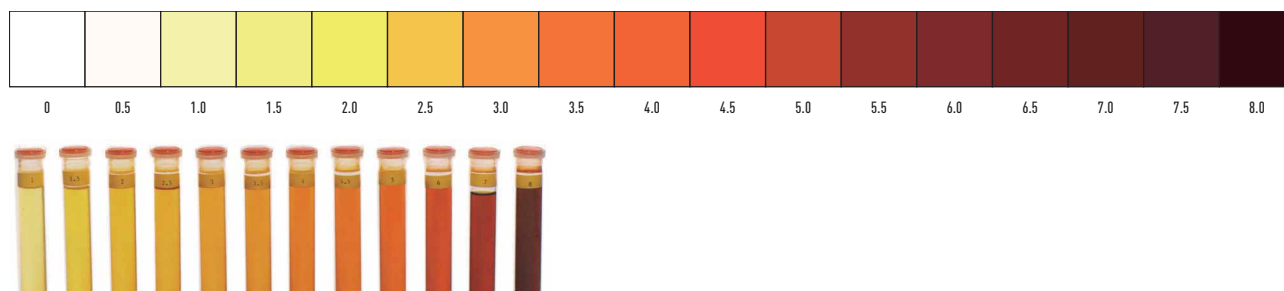

ACCESSORIES & CONTROL

Panels



CZ-KPU3
Normal panel for 90x90 Cassette PUZ.



CZ-KPU3A
Econavi panel for 90x90 Cassette PUZ.



CZ-KPY3AW
Panel for 60x60 Cassette size 700x700mm.



CZ-KPY3BW
Panel for 60x60 Cassette size 625x625mm.

Other Accessory

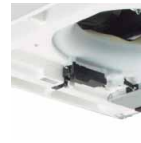

CZ-CNEXU1
nanoe™ X air purifying system for 90x90 Cassette PUZ.



CZ-CENSC1
Econavi energy savings sensor.

Outdoor accessories

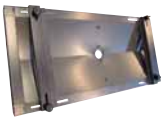

PAW-WTRAY
Tray for condenser water compatible with base ground support.



PAW-GRDSTD40
Outdoor elevation platform 400x900x400mm.



PAW-GRDBSE20
Outdoor base ground support for noise and vibration absorption (600 x 95 x 130mm, 500kg).

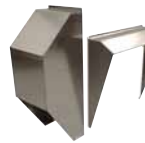

PAW-WPH7
Wind protection shield for 7,1kW Elite and 10,0 and 12,5kW Standard outdoor units.



PAW-WPH9
Wind protection shield for 3,6, 5,0 and 6,0kW Elite and 6,0 and 7,1kW Standard outdoor units.

PAW-WPH8
Wind protection shield for U-200PE2E8A, U-250PE2E8A.

PAW-WPH10
Wind protection shield for 10,0, 12,5 and 14,0kW Elite and 14,0kW Standard outdoor units.

Branch Pipes, Header

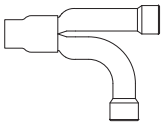

CZ-P155BK1
Branch pipe (capacity after distribution is 16,0kW or less).

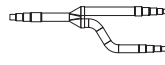

CZ-P224BK2BM
Branch pipe (capacity after distribution is 22,4kW or less).

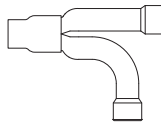

CZ-P680BK2BM
Branch pipe (from 22,4kW to 68kW).

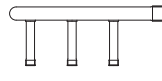

CZ-P3HPC2BM
Header.

Plenums



CZ-DUMPA160MF2
Air Inlet Plenum S .PF1E5B 100, 125 & 140.

CZ-56DAF2
Air Outlet Plenum S .PF1E5B 36, 45 & 50.

CZ-90DAF2
Air Outlet Plenum S .PF1E5B 60 & 71.

CZ-160DAF2
Air Outlet Plenum S .PF1E5B 100, 125 & 140.

CZ-TREMIESPW705
Air Outlet Plenum S-200PE2E5.

CZ-TREMIESPW706
Air Outlet Plenum S-250PE2E5.

Individual Controls



CZ-RTC5B
Design wired remote controller with Econavi button and datanavi.



CZ-RTC4
Remote controller for maintenance setting.



CZ-RE2C2
Simplified remote control.



CZ-RWSU3
Wireless remote control for 90x90 Cassette PUZ.

Controller for Hotels with Dry Contacts



PAW-RE2C3-WH
Stand-Alone with I/O White frame.

PAW-RE2C3-MOD-WH
Modbus RS-485 with I/O White frame.

PAW-RE2C3-MOD-WH
Modbus RS-485 with I/O White frame.

PAW-RE2C3-GR
Stand-Alone with I/O Grey frame.

PAW-RE2C3-MOD-GR
Modbus RS-485 with I/O Grey frame.

PAW-RE2C3-MOD-GR
Modbus RS-485 with I/O Grey frame.

Centralised Controls



CZ-RWST3N
Wireless remote control for Ceiling.



CZ-RWSK2
Wireless remote control for Wall mounted (and CZ-RWSC3).



CZ-RWSC3
Wireless receiver kit (need CZ-RWSK2 separately).



CZ-CSRC3
Temperature Remote sensor.



CZ-64ESMC3
System Controller with Schedule timer. Operation with various function from center station.



CZ-ANC3
Central On/Off controller, up to 16 groups, 64 indoor units.



CZ-256ESMC3
Simplified load distribution ratio (LDR) for each tenant. Intelligent Controller (Touch screen panel).

Centralised Controls. BMS System. PC Base



CZ-CSWKC2
PAIMS Basic software.

CZ-CSWAC2
PAIMS Consumption calculation control.

CZ-CSWGC2
PAIMS - Layout display.

CZ-CAPDC2
Serial parallel device controlling outdoor units, up to 4 units.



CZ-CAPC3
Adaptor for On/off control of external devices.



CZ-CAPBC2
Mini series parallel device controlling indoor units, maximum 1 group and 8 indoor unit.



CZ-CFUNC2
Communication Adaptor. Up to 128 groups. Controls 128 units.

CZ-CFUNC2
Communication adaptor.

CZ-CSWBC2
PAIMS - BACnet interface.

CZ-CSWWC2
PAIMS - Web application.

VRF Smart Connectivity



SER8150R0B1194
Remote Controller Panasonic Net Con, RH, No PIR, R1/R2.



VCM8000V5094P
Panasonic R1R2 to Zigbee adaptor box No Brand.



SED-WMS-P-5045
Wireless Sensors Wall motion sensor.



SED-WDS-P-5045
Wireless Sensors Door/window contact.



SED-CMS-P-5045
Wireless Sensors Ceiling motion sensor.

SED-CO2-G-5045
CO₂ sensor.

SER8150R5B1194
Remote Controller Panasonic Net Con, RH, PIR, R1/R2.

VCM8000V5094G
(For Wave1) Wireless Zigbee Pro / Green Com card (required in case Wave1 wired product need to do MPM connection).

Accessories Interfaces



PAW-RC2-WIFI-1
Interface for Intesishome for PACi & ECOi.



PAW-RC2-KNX-1i
KNX Interface.



PAW-RC2-MBS-4
Modbus interface to control 4 indoor/groups.



PAW-RC2-MBS-1
Modbus Interface.



PAW-MBS-TCP2RTU
ModBus RTU Slave devices.



PAW-RC2-BAC-1
BACnet Interface.



CZ-CAPRA1
Domestic with CZ-CNT port integration to PACi and ECOi.

Accessories PCB



PAW-T10
All T10 functions.

PAW-T10V
All T10 functions + power monitoring.

PAW-T10H
ON/OFF; Prohibit 5VDC & 230VAC.

PAW-T10HW
ON/OFF; Prohibit 5VDC.



PAW-PACR3
Redundancy of 2 or 3 systems; for PACi and ECOi.



PAW-SERVER-PKEA
Redundancy of 2 units PKEA.

Panasonic AC Smart Cloud



CZ-CFUSCC1
Panasonic AC Smart Cloud. Cloud internet control. Up to 128 groups. Controls 128 units.

Accessories Cables



CZ-T10
Cable for all the T10 functions.



PAW-FDC
Cable to operate external EC fan.



PAW-OCT
Cable for all option monitoring signals.



CZ-CAPE2
Option monitoring signals w/o Fan.

PAW-EXCT
Cable with force Thermo OFF/leakage Detection.